



YESCHAMP IMP & EXP (TAIZHOU) CO., LTD.

Add: F3 Purity Building, No.6 Dong'an South
RD., Daxi Town, Wenling, Zhejiang, China

Tel: +86-576-86090666

Website: www.yeschamp.com

E-mail: info@yeschamp.com

Wechat/Whatsapp: +86-18667600006



CHL/CHLK/CHLF

Light Horizontal Multistage Centrifugal Pump

2021



● Performance scope

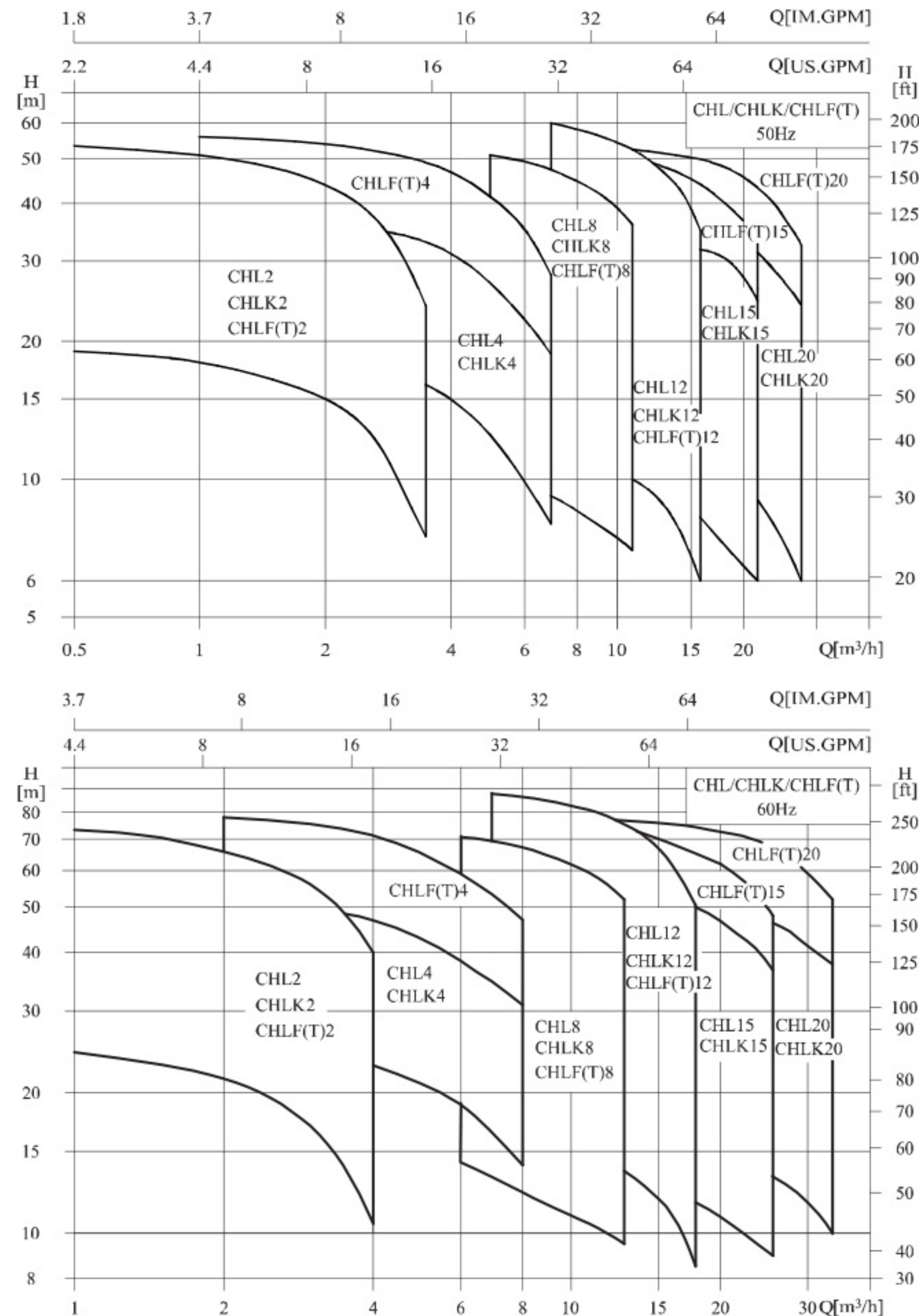

● Application

CHL,CHLK and CHLF(T) type pump are mainly used in industrial field:

- Air-conditioning system
- Cooling system
- Industrial cleaning
- Water treatment (Water purification)
- Aquiculture
- Fertilizing / metering system
- Environmental application
- Other special applications

● Applicable medium

- Thin and clean non-flammable and non-explosive liquid without solid granules and fibers.
- Mineral water, soft water, pure water, edible vegetable oil and other light chemical mediums.
- When the density or viscosity of to-be-conveyed liquid is larger than that of water, it is necessary to select a driving motor of high-power.
- Whether a specific liquid is suitable for the pump depends on many factors, among which the most important ones are chlorine content, PH value, temperature, solvent and oil content.

● Pump

- Horizontal multistage non-self-priming centrifugal pump, attached with long shaft electric motor.
- Compact structure renders small size of pump; axial inlet and radial outlet.

● Curve conditions

Following conditions are suitable for the performance curves shown above.

- All curves are based on the measured values of 50Hz: constant motor speed 2900r/min, 60 Hz: constant motor speed 3500 r/min;
- Curve tolerance in conformity to ISO9906:2012 Grade 3B.
- Measurement is done with 20°C air-free water, kinematic viscosity of 1mm²/sec.
- The operation of pump shall refer to the performance region described by the thickened curve to prevent overheating due to too small flow rate or overload of motor due to too large flow rate.

● Motor

- TEFC motor 2-pole
- Protection class:IP55
- Insulation class:F
- Standard voltage, 50Hz: 1 × 220-240V
3 × 220-240V/380-415V
- Standard voltage, 60Hz: 1 × 220-240V
3 × 220-240V/380-415V
- Single phase motor (max) : 2.4kW

● Operation condition

- Liquid temperature:
Normal temperature type: -15°C ~ +70°C
Hot water type: -15°C ~ +105°C
- Ambient temperature: up to +40°C
- Max.operation pressure: 10 bar
- Max.inlet pressure is limited by max. Operation pressure

Connection port	CHL/CHLK/CHLF(T)2	CHL/CHLK/CHLF(T)4	CHL/CHLK, 12,15,20	CHLF(T)8	CHLF(T)12	CHLF(T)15,20
Inlet	G1	G1 $\frac{1}{4}$	G2	G1 $\frac{1}{2}$	G1 $\frac{1}{2}$	G2
Outlet	G1	G1	G2	G1 $\frac{1}{4}$	G1 $\frac{1}{2}$	G2

● Definition of Model

CHL Example

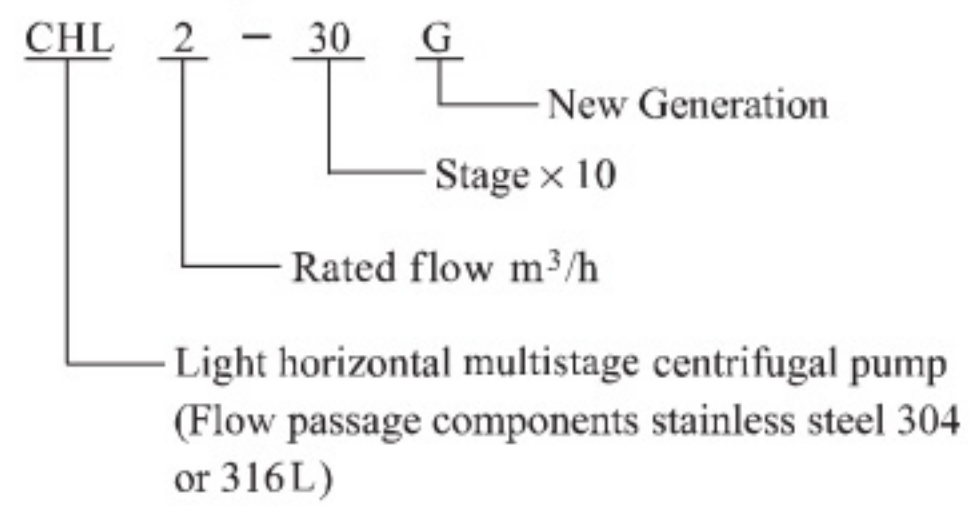

CHLK Example

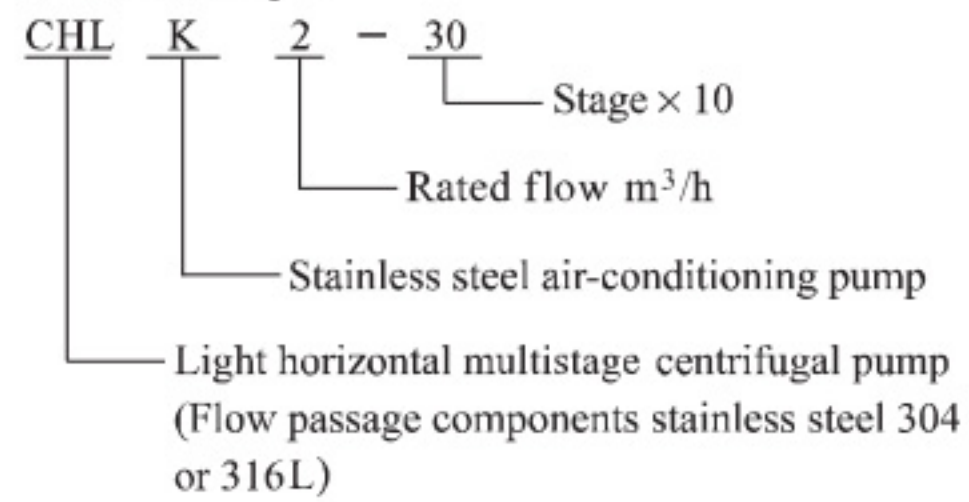

CHLF(T) Example

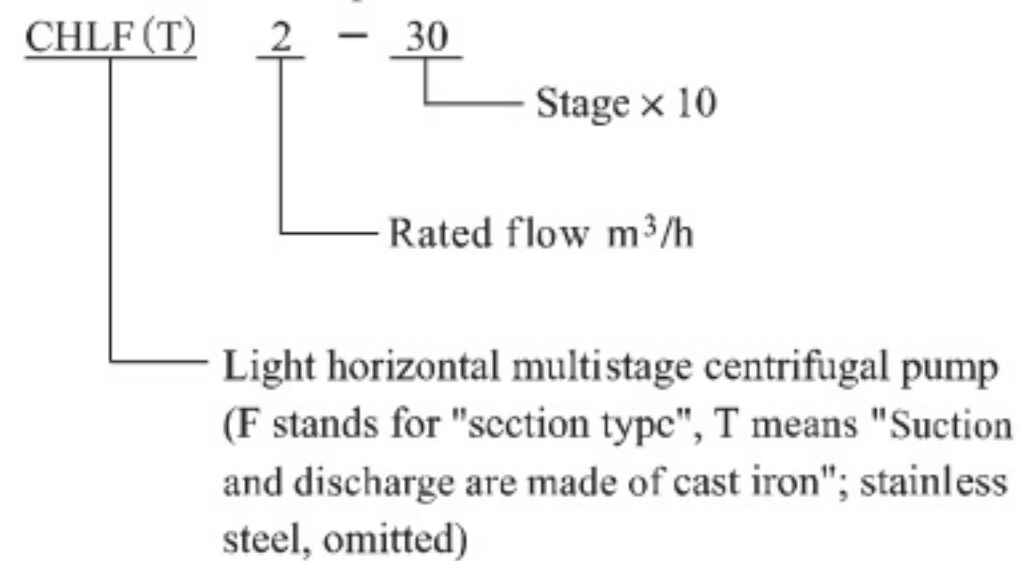

● Material CHL/CHLK

No.	Name	Material	AISI / ASTM
1	Inlet and outlet chamber	Stainless steel	AISI304
2	Connection pipe	Stainless steel	AISI304
3	Clamp plate	Stainless steel	AISI304
4	Impeller	Stainless steel	AISI304
5	Shaft	Stainless steel	AISI304
6	Plug	Stainless steel	AISI304
7	Discharge diffuser	Stainless steel	AISI304
8	Mechanical seal		
9	Motor end cover	Aluminum alloy	
10	Base plate	Steel plate	AISI1015
11	Spannband	Stainless steel	AISI304
12	Diffuser	Stainless steel	AISI304
13	Support diffuser	Stainless steel	AISI304
14	Inducer	Stainless steel	AISI304

● Material CHLF/CHLF(T)

No.	Name	Material	AISI / ASTM
2	Plug	Stainless steel	AISI304
3	Bearing	Tungsten carbide	
4	Impeller	Stainless steel	AISI304
5	Shaft	Stainless steel	AISI304
8	Mechanical seal		
9	Motor end cover	Aluminum alloy	
10	Base plate	Steel plate	AISI1015
11	Staybolt	Stainless steel	AISI304
12	Diffuser	Stainless steel	AISI304
13	Support diffuser	Stainless steel	AISI304
14	Impeller sleeve	Stainless steel	AISI304

CHLF

1	Suction	Stainless steel	AISI304
7	Discharge	Stainless steel	AISI304

CHLF(T)

1	Suction	Cast iron	ASTM25B
7	Discharge	Cast iron	ASTM25B

● Section drawing CHL,CHLK2,4

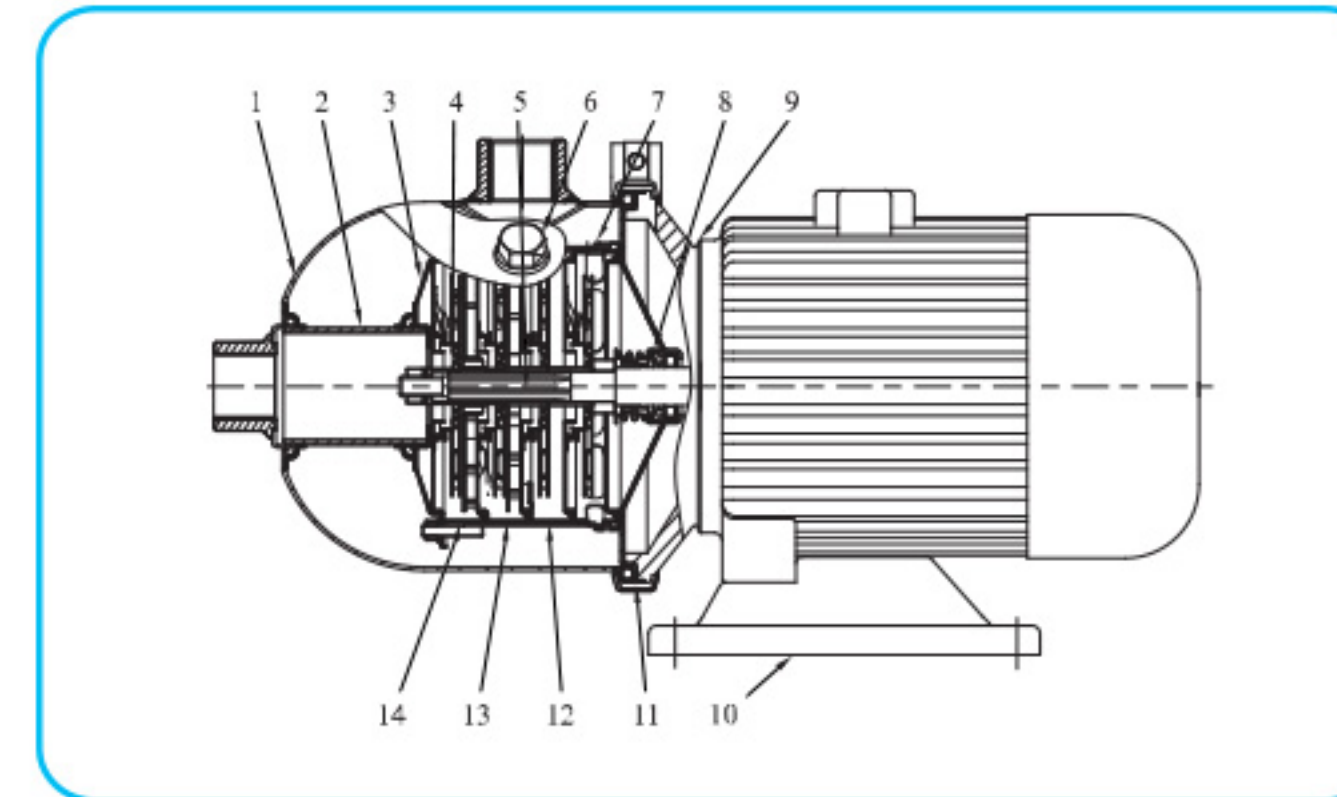

● Section drawing CHL,CHLK8,12,15,20

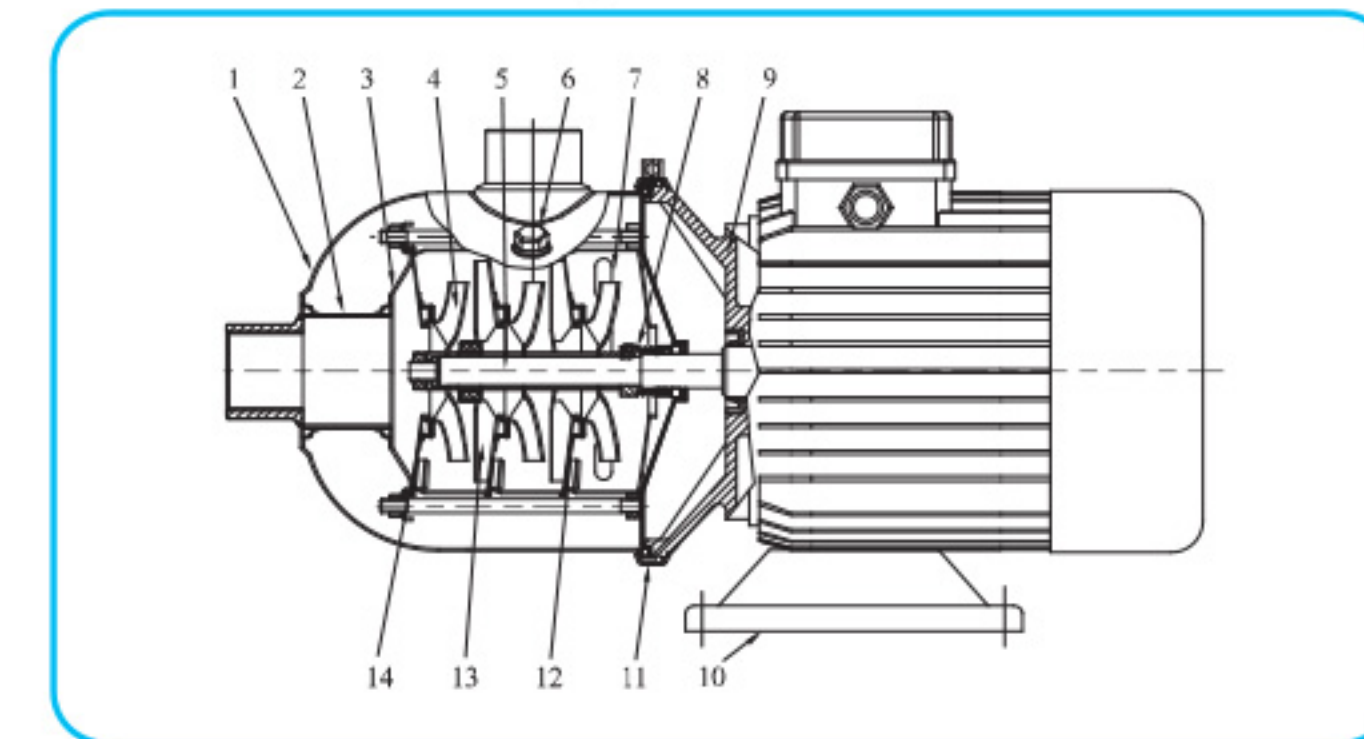

● Section drawing CHLF,CHLF(T)

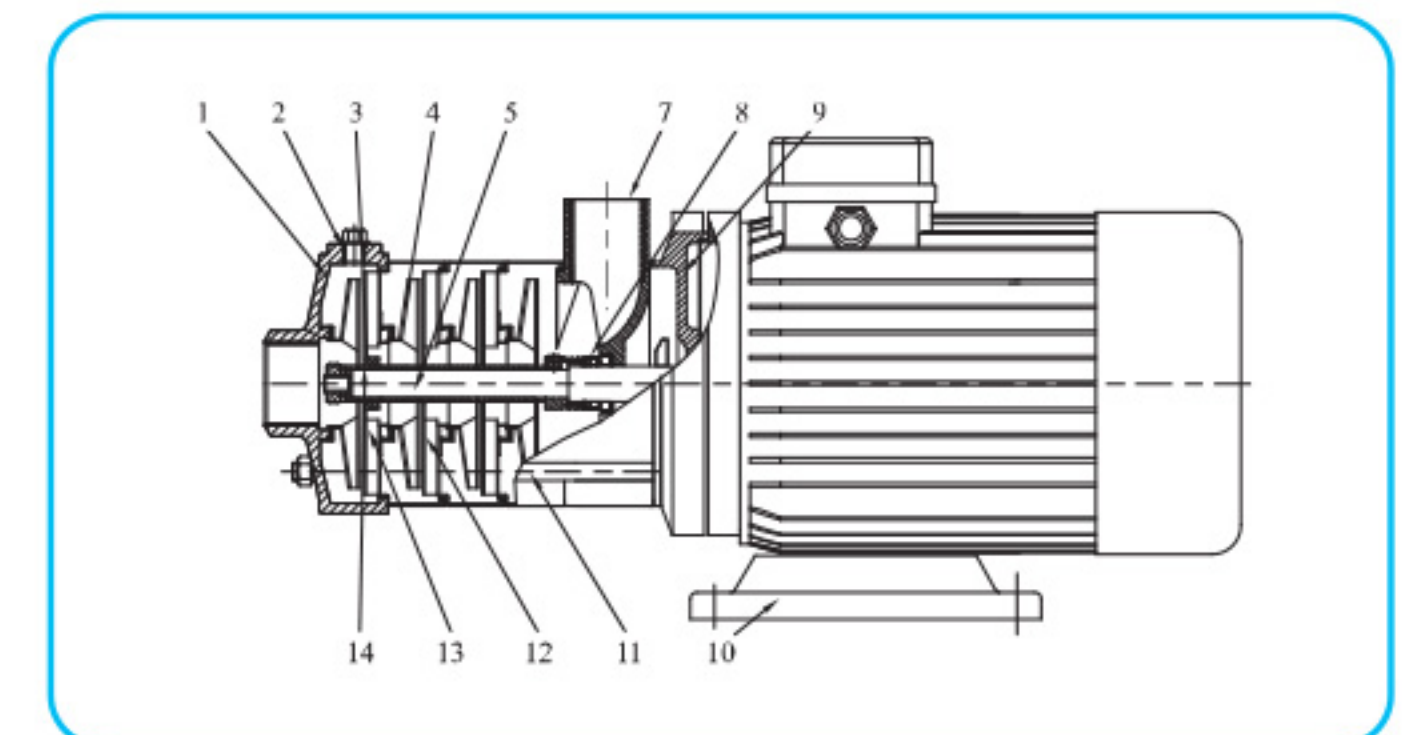

Performance curve

ISO9906:2012,3B

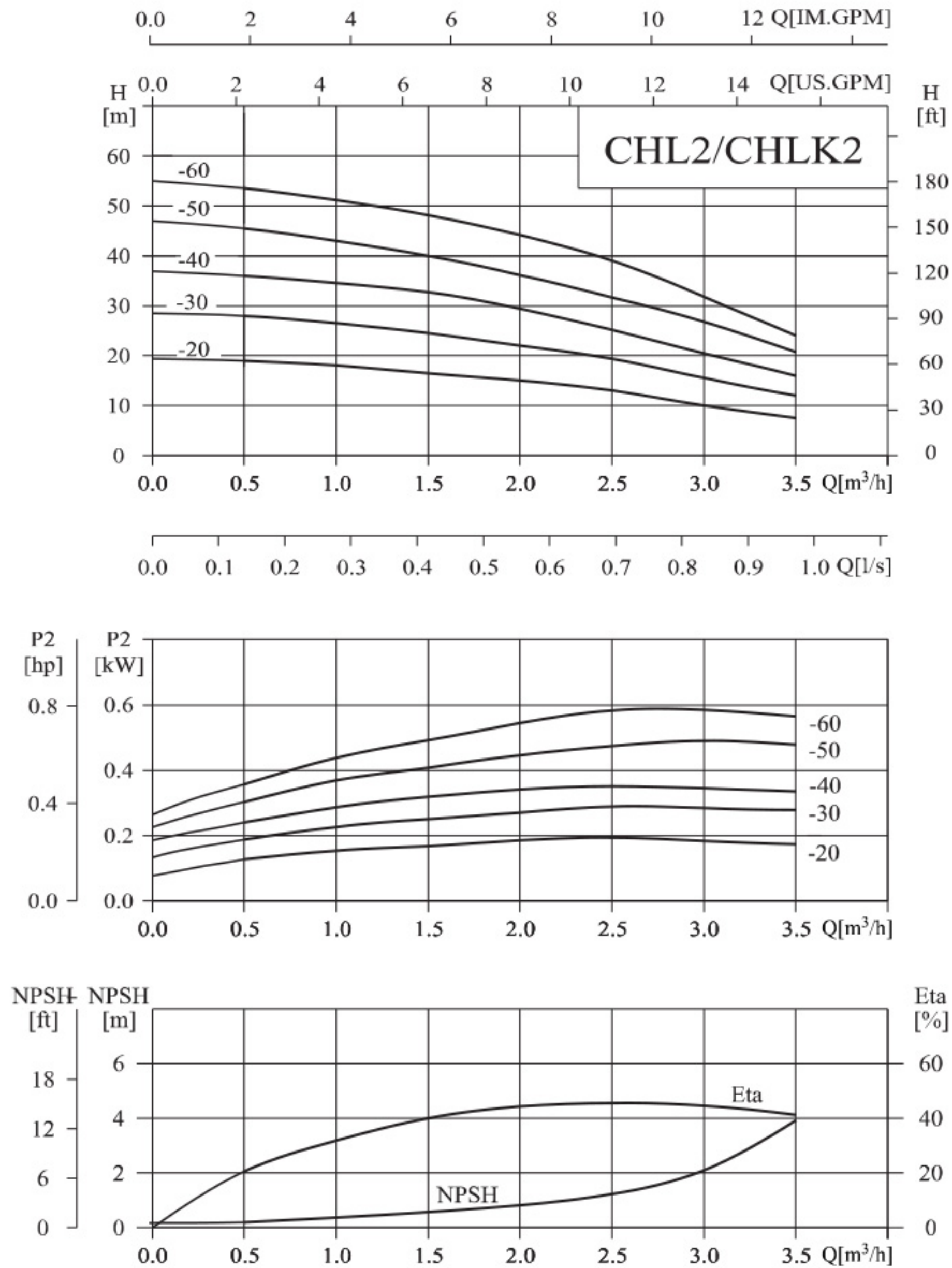

Performance table

Model	Driving motor		Q (m³/h)	0.5	1	1.5	2	2.5	3	3.5
	(kW)	(hp)								
CHL2-20	0.37	0.5	H (m)	19	18	16.5	15	13	10	7.5
CHL2-20G	0.37	0.5		19	18	16.5	15	13	10	7.5
CHL2-30	0.37	0.5		28	26.5	24.5	22	19	15.5	12
CHL2-30G	0.37	0.5		28	26.5	24.5	22	19	15.5	12
CHL2-40	0.55	0.75		36	34.5	33	29	25	20.5	16
CHL2-40G	0.55	0.75		36	34.5	33	29	25	20.5	16
CHL2-50	0.55	0.75		45.5	43	40	36	31.5	26.5	20.5
CHL2-60	0.75	1		53.5	51	48	44	39	32	24

Installation sketch

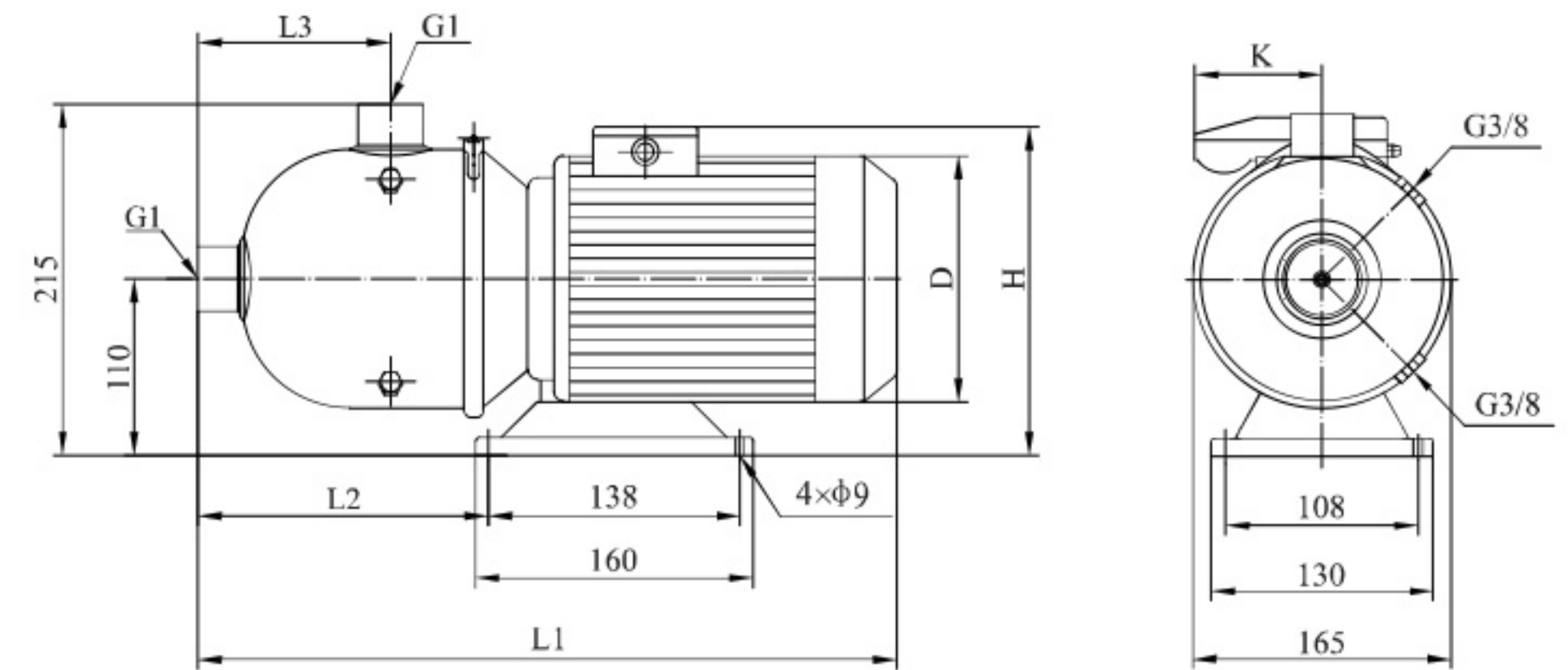

Size and weight

Motor	Model	Size (mm)						Weight (kg)
		L1	L2	L3	D	H	K	
Three-phase/ single-phase	CHL2-20	400	165	125	141	215/249	/62	10
	CHL2-20G	360	125	85	141	215/249	/62	10
	CHL2-30	400	165	125	141	215/249	/62	10
	CHL2-30G	360	125	85	141	215/249	/62	10
	CHL2-40	400	165	125	141	215/249	/62	11
	CHL2-40G	360	125	85	141	215/249	/62	11
	CHL2-50	400	165	125	141	215/249	/62	12
	CHL2-60	420	165	125	151/161	225/265	/91	14

● Performance curve

ISO9906:2012,3B

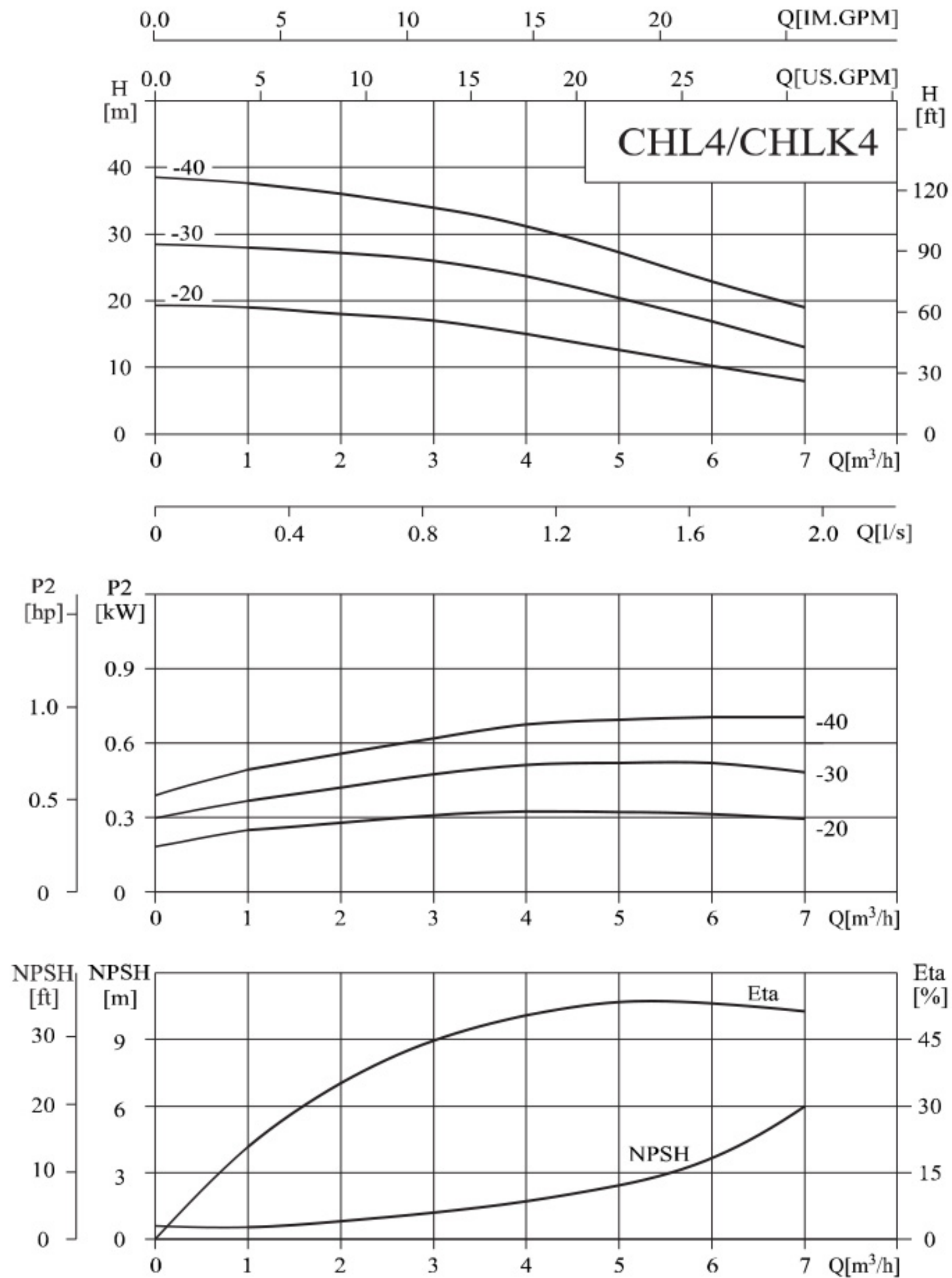

● Performance table

Model	Driving motor		Q (m³/h)	1	2	3	4	5	6	7
	(kW)	(hp)								
CHL4-20	0.37	0.5	H (m)	19	18	17	15	12.5	10	8
CHL4-20G	0.37	0.5		19	18	17	15	12.5	10	8
CHL4-30	0.55	0.75		28	27	26	23.5	20.5	17	13
CHL4-40	0.75	1		37.5	36	34	31	27	23	19

● Installation sketch

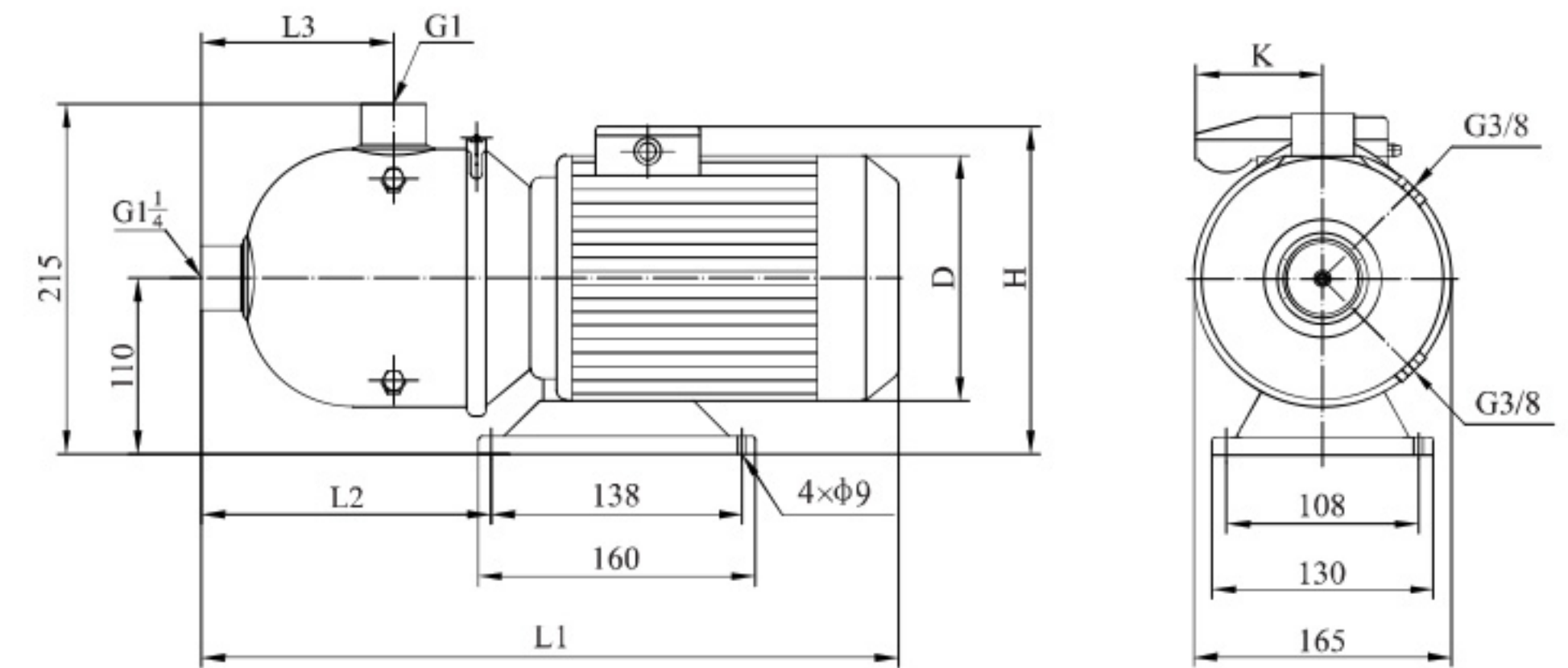

● Size and weight

Motor	Model	Size (mm)						Weight (kg)
		L1	L2	L3	D	H	K	
Three-phase/ single-phase	CHL4-20	400	172	132	141	215/249	/62	10
	CHL4-20G	360	132	92	141	215/249	/62	10
	CHL4-30	400	172	132	141	215/249	/62	11
	CHL4-40	420	172	132	151/161	225/265	/91	14

Performance curve

ISO9906:2012,3B

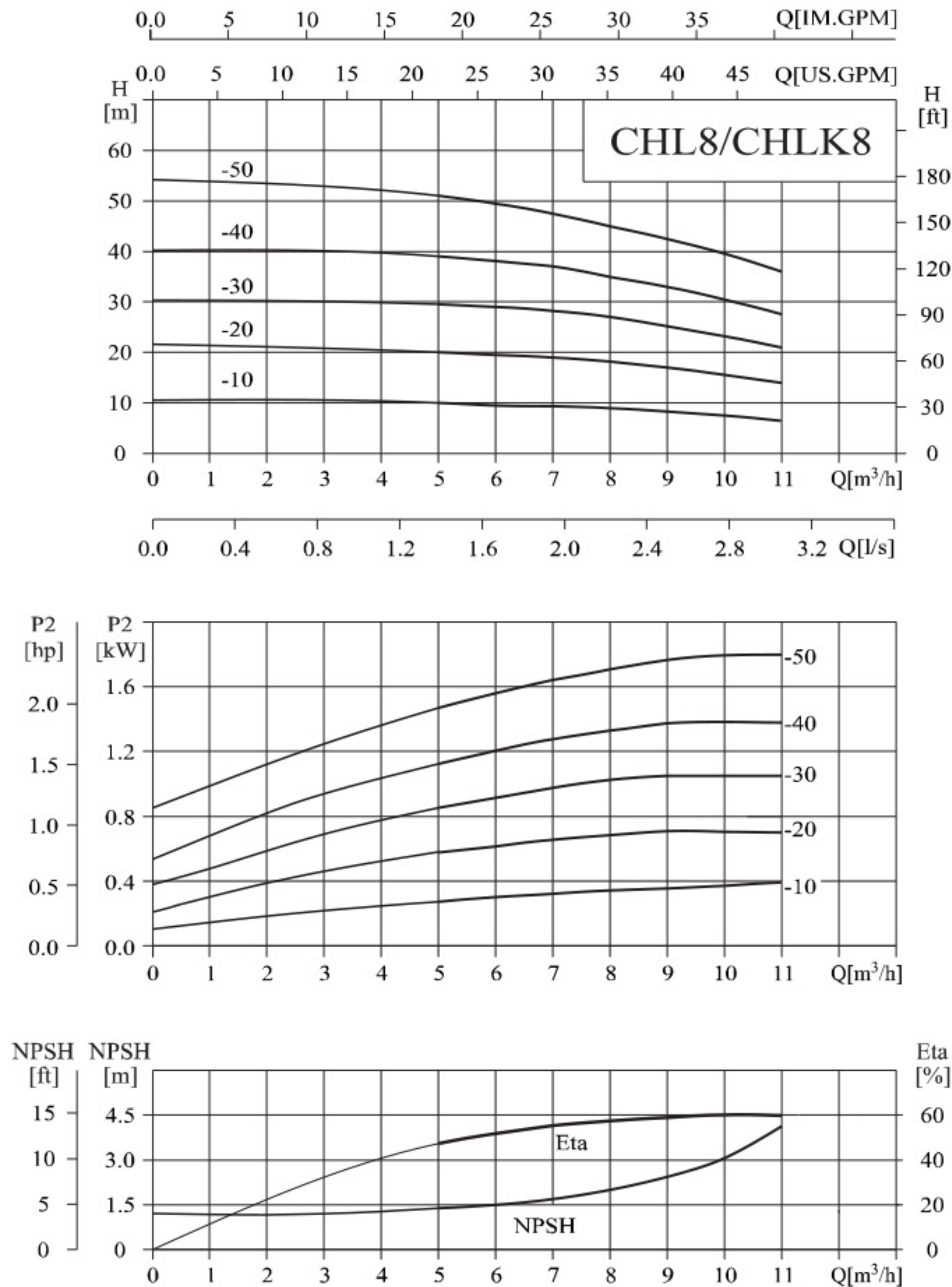

Performance table

Model	Driving motor		Q (m³/h)	5	6	7	8	9	10	11
	(kW)	(hp)								
CHL8-10	0.75	1	H (m)	10	9.5	9.3	9	8	7.5	7
CHL8-10G	0.75	1		10	9.5	9.3	9	8	7.5	7
CHL8-20	0.75	1		20	19.5	19	18	17	15.5	14
CHL8-20G	0.75	1		20	19.5	19	18	17	15.5	14
CHL8-30	1.1	1.5		29.5	29	28	27	25	23	21
CHL8-30G	1.1	1.5		29.5	29	28	27	25	23	21
CHL8-40	1.5	2		39	38	37	35	33	30.5	27.5
CHL8-50	2.2	3		51	49.5	47.5	45	42.5	39.5	36

Installation sketch

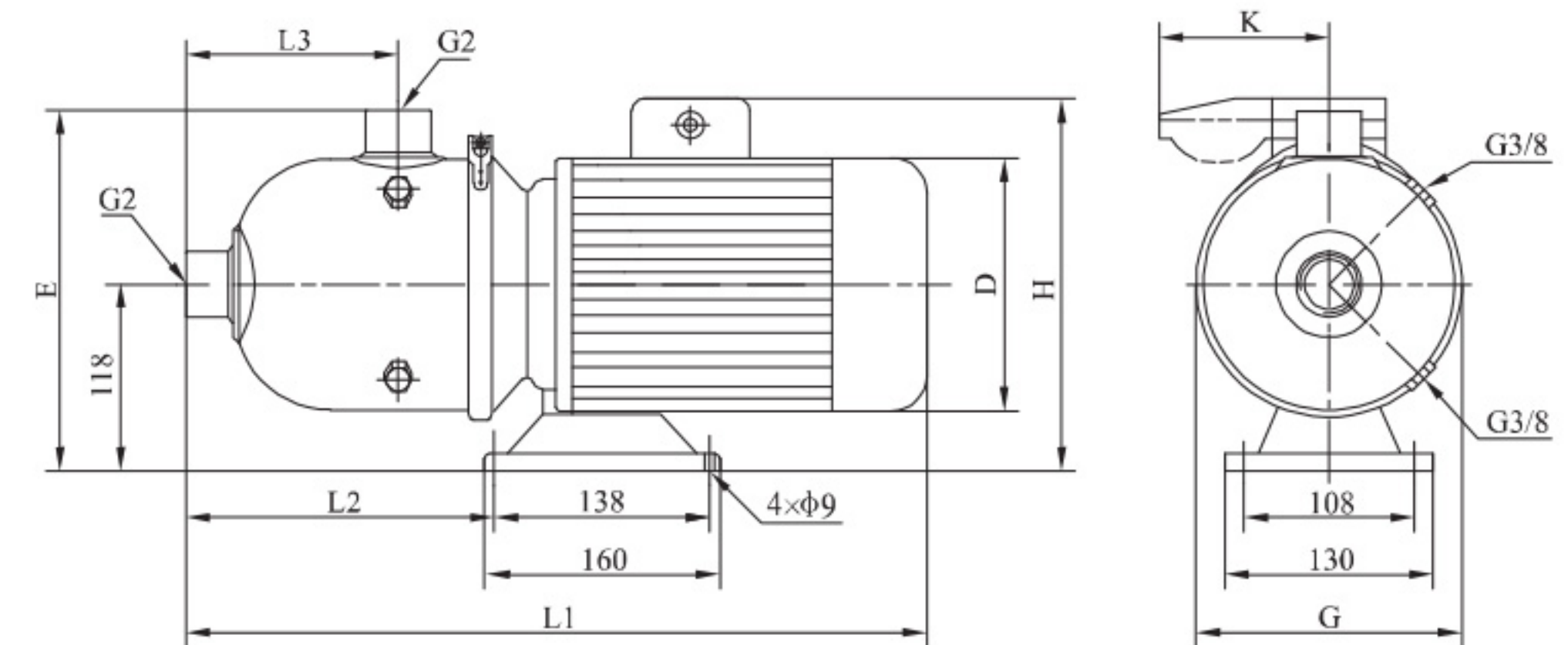

Size and weight

Motor	Model	Size (mm)								Weight (kg)
		L1	L2	L3	E	G	D	H	K	
Three-phase/ single-phase	CHL8-10	530	279	176	264	223	151/161	225/265	/91	18
	CHL8-10G	480	199	95	249	193	151/161	225/265	/91	17
	CHL8-20	530	279	176	264	223	151/161	225/265	/91	19
	CHL8-20G	480	199	95	249	193	151/161	225/265	/91	18
	CHL8-30	530	279	176	264	223	151/161	230/265	/91	22
	CHL8-30G	480	199	95	249	193	151/161	230/265	/91	21
	CHL8-40	563	279	176	265	223	171/176	235/270	/91	27
	CHL8-50	563	279	176	265	223	171/176	235/270	/91	32

Performance curve

ISO9906:2012,3B

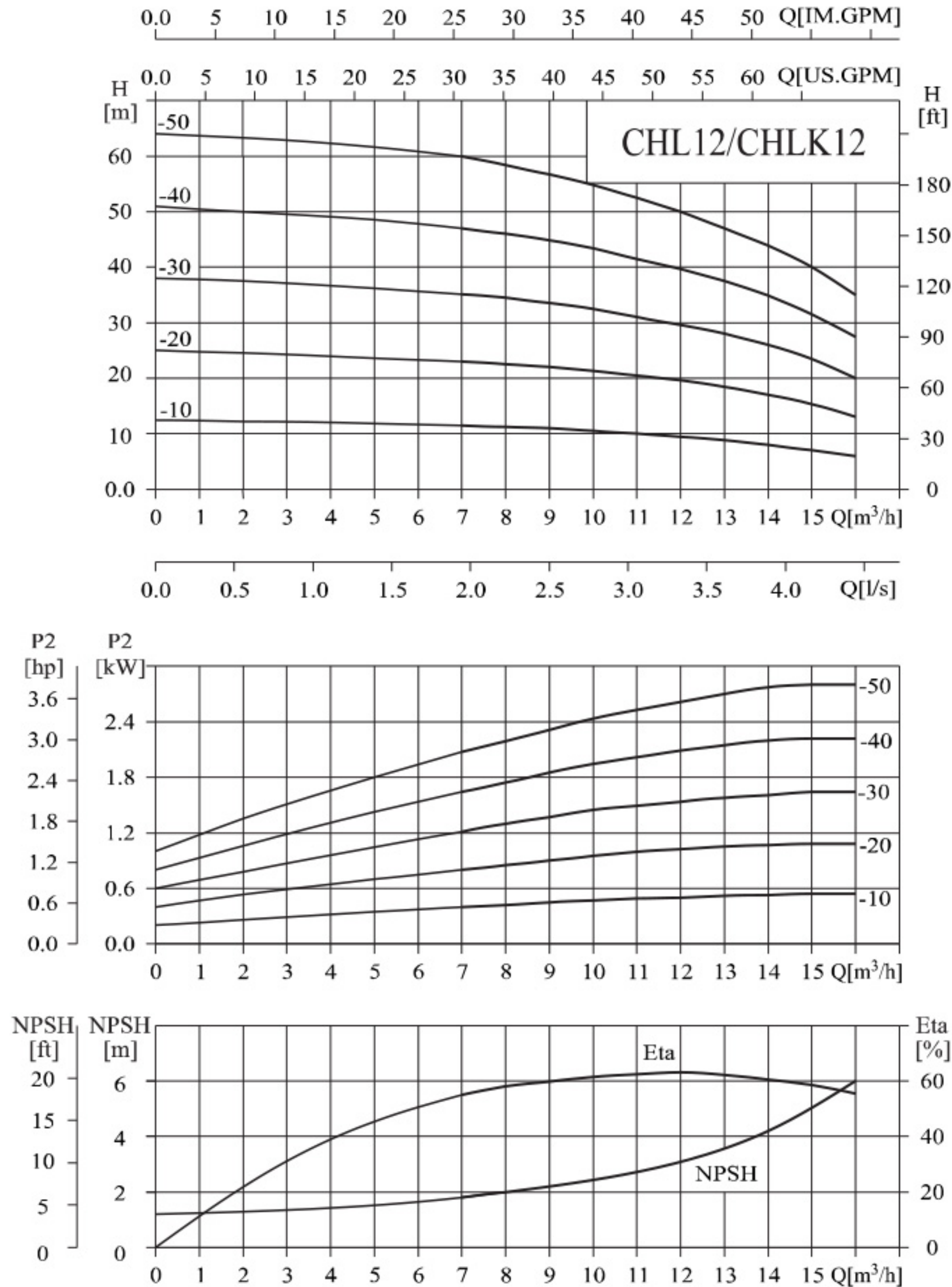

Performance table

Model	Driving motor		Q (m³/h)	7	8	9	10	11	12	13	14	15	16
	(kW)	(hp)											
CHL12-10	0.75	1	H (m)	11.5	11.2	11	10.5	10	9.5	9	8	7	6
CHL12-10G	0.75	1		11.5	11.2	11	10.5	10	9.5	9	8	7	6
CHL12-20	1.2	1.6		23	22.5	22	21.5	20.5	19.5	18.5	17	15.5	13
CHL12-20G	1.2	1.6		23	22.5	22	21.5	20.5	19.5	18.5	17	15.5	13
CHL12-30	1.8	2.4		35	34.5	33.5	32.5	31	29.5	28	26	23.5	20
CHL12-30G	1.8	2.4		35	34.5	33.5	32.5	31	29.5	28	26	23.5	20
CHL12-40	2.4	3.3		47	46	45	43.5	41.5	39.5	37.5	35	31.5	27.5
CHL12-50	3	4		60	58	56.5	55	52.5	50	47	44	40	35

Installation sketch

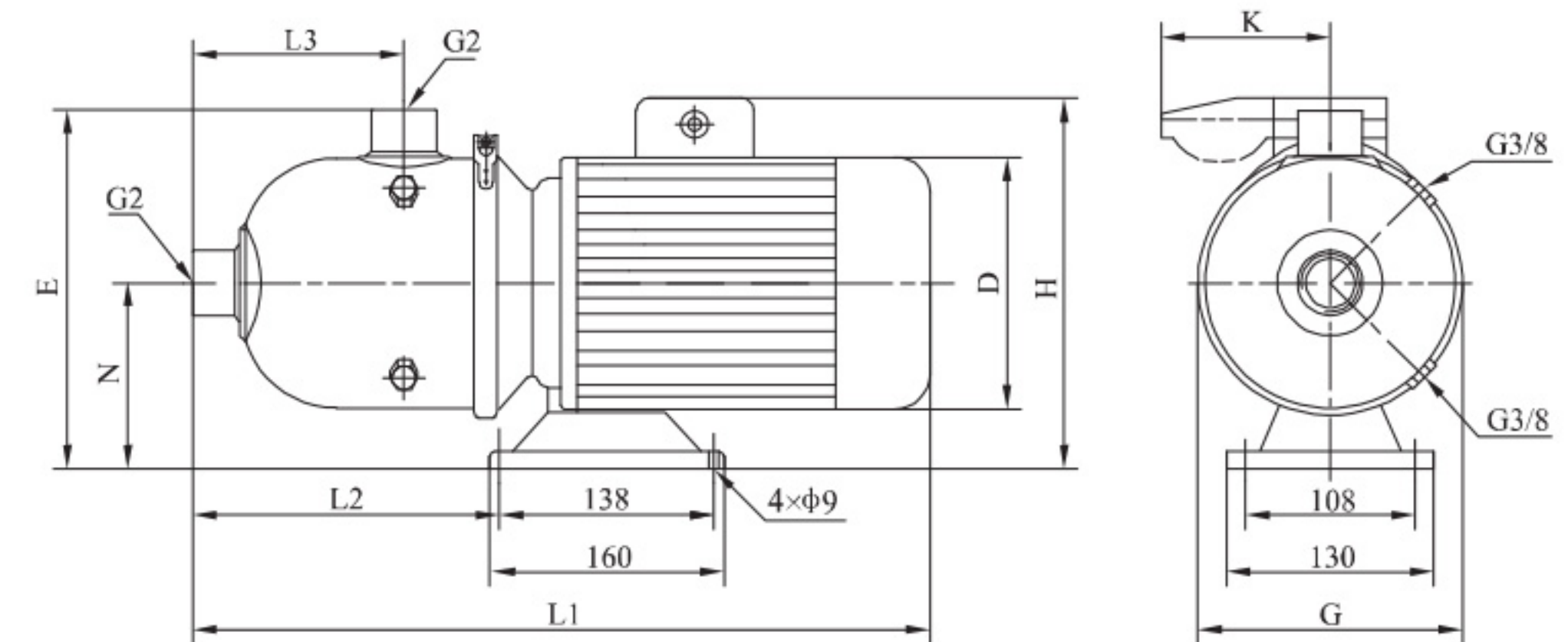

Size and weight

Motor	Model	Size (mm)									Weight (kg)
		L1	L2	L3	N	E	G	D	H	K	
Three-phase/ single-phase	CHL12-10	530	279	176	117	264	223	151/161	225/265	/91	18
	CHL12-10G	480	199	95	117	249	193	151/161	225/265	/91	17
	CHL12-20	530	279	176	117	264	223	151/161	225/265	/91	22
	CHL12-20G	480	199	95	117	249	193	151/161	225/265	/91	21
	CHL12-30	563	279	176	118	265	223	171/176	235/270	/91	28
	CHL12-30G	490	199	95	118	250	193	171/176	235/270	/91	27
	CHL12-40	563	279	176	118	265	223	171/176	235/270	/91	33
	CHL12-50	610	279	176	128	275	223	196/	259/		37

Performance curve

ISO9906:2012,3B

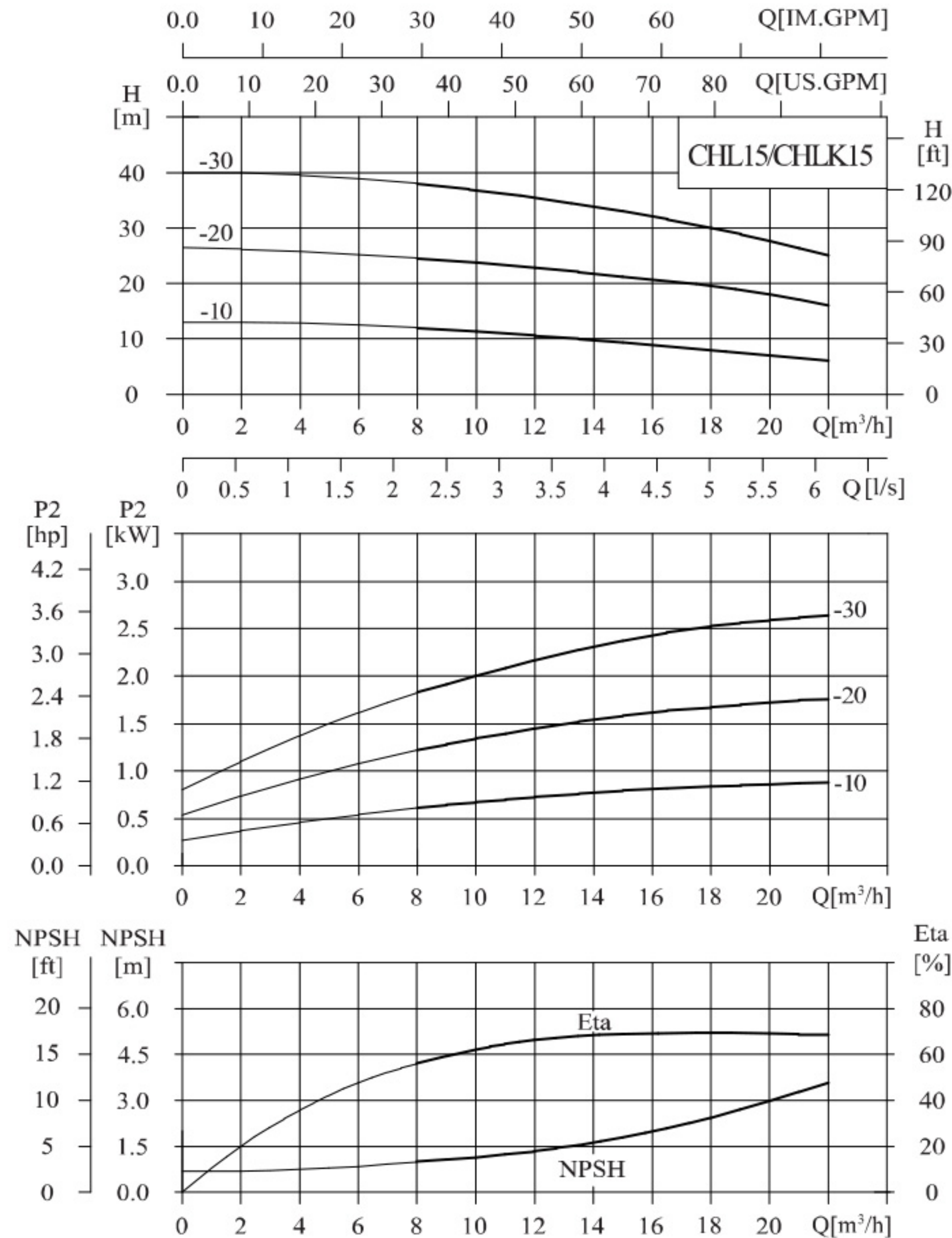

Performance table

Model	Driving motor		Q (m³/h)	8	10	12	14	15	16	18	20	22
	(kW)	(hp)		H (m)								
CHL15-10	1.1	1.5	H (m)	12	11	10.5	9.5	9	8.5	7.5	6.5	6
CHL15-20	2.2	3		24.5	24	23	22	21	20.5	19	18	16
CHL15-30	3	4		38	37	35.5	34	33	32	30	28	25

Installation sketch

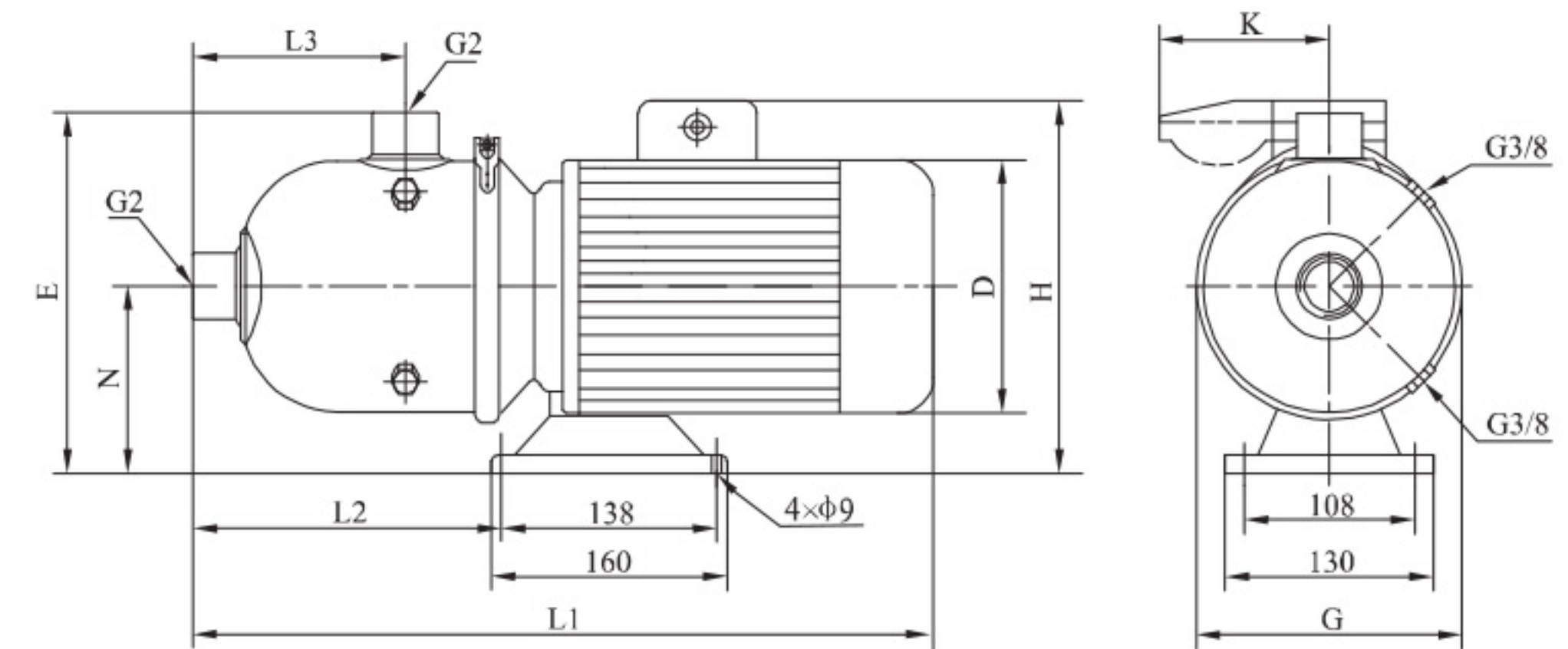

Size and weight

Motor	Model	Size (mm)									Weight (kg)
		L1	L2	L3	N	E	G	D	H	K	
Three-phase/ single-phase	CHL15-10	530	279	176	117	264	223	151/161	225/265	/91	20
	CHL15-20	563	279	176	118	265	223	171/176	235/270	/91	26
	CHL15-30	605	279	176	128	275	223	196/	259/		34

Performance curve

ISO9906:2012,3B

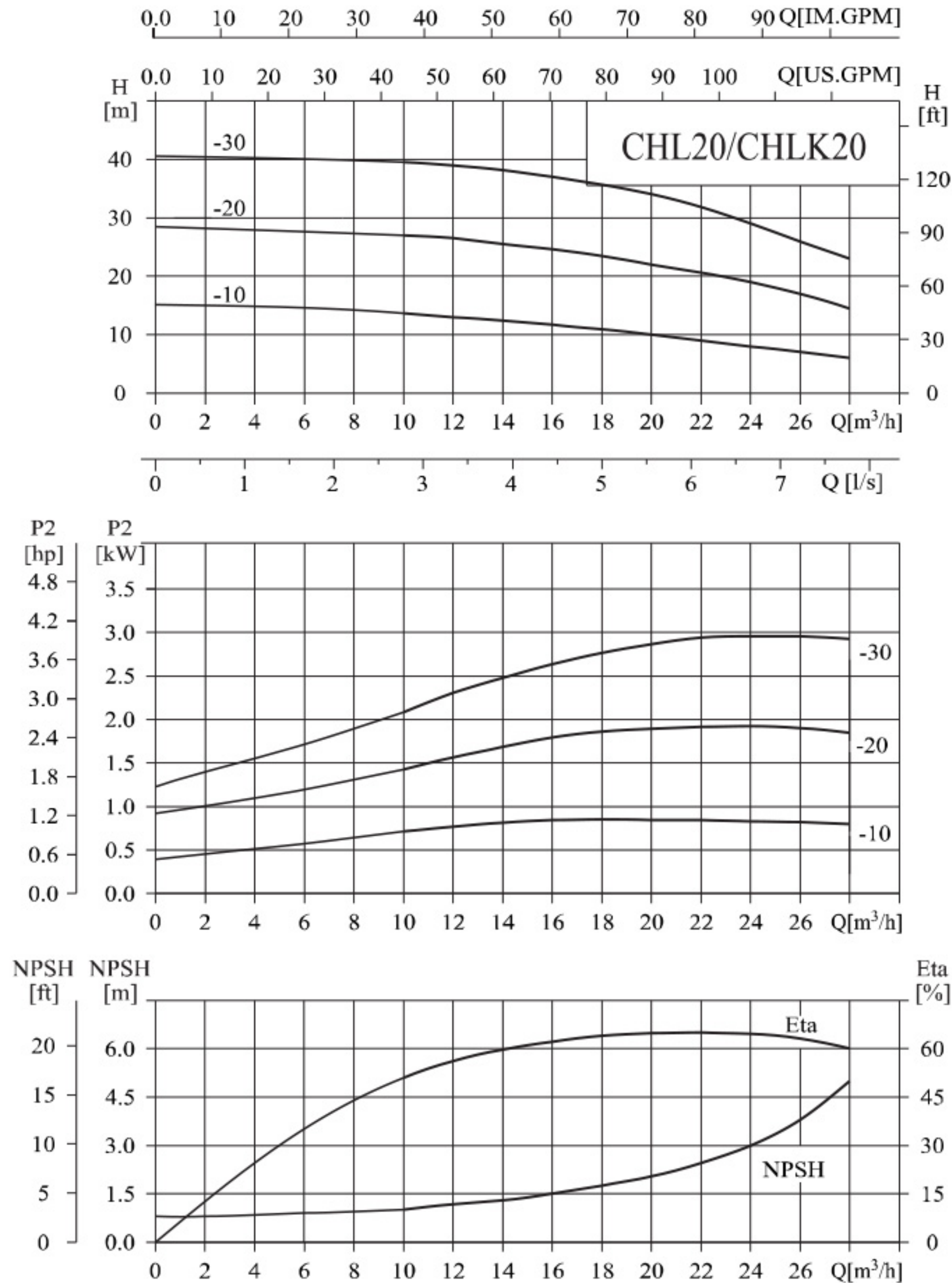

Performance table

Model	Driving motor		Q (m³/h)	10	12	14	16	18	20	22	24	26	28
	(kW)	(hp)		H (m)									
CHL20-10	1.1	1.5	H (m)	13.5	13	12.5	12	11	10	9	8	7	6
CHL20-10G	1.1	1.5		13.5	13	12.5	12	11	10	9	8	7	6
CHL20-20	2.2	3		27	26.5	25.5	25	23.5	22	20.5	18.5	17	14.5
CHL20-20G	2.2	3		27	26.5	25.5	25	23.5	22	20.5	18.5	17	14.5
CHL20-30	4	5.5		39.5	39	38	37.5	35.5	34	31.5	29	26	23

Installation sketch

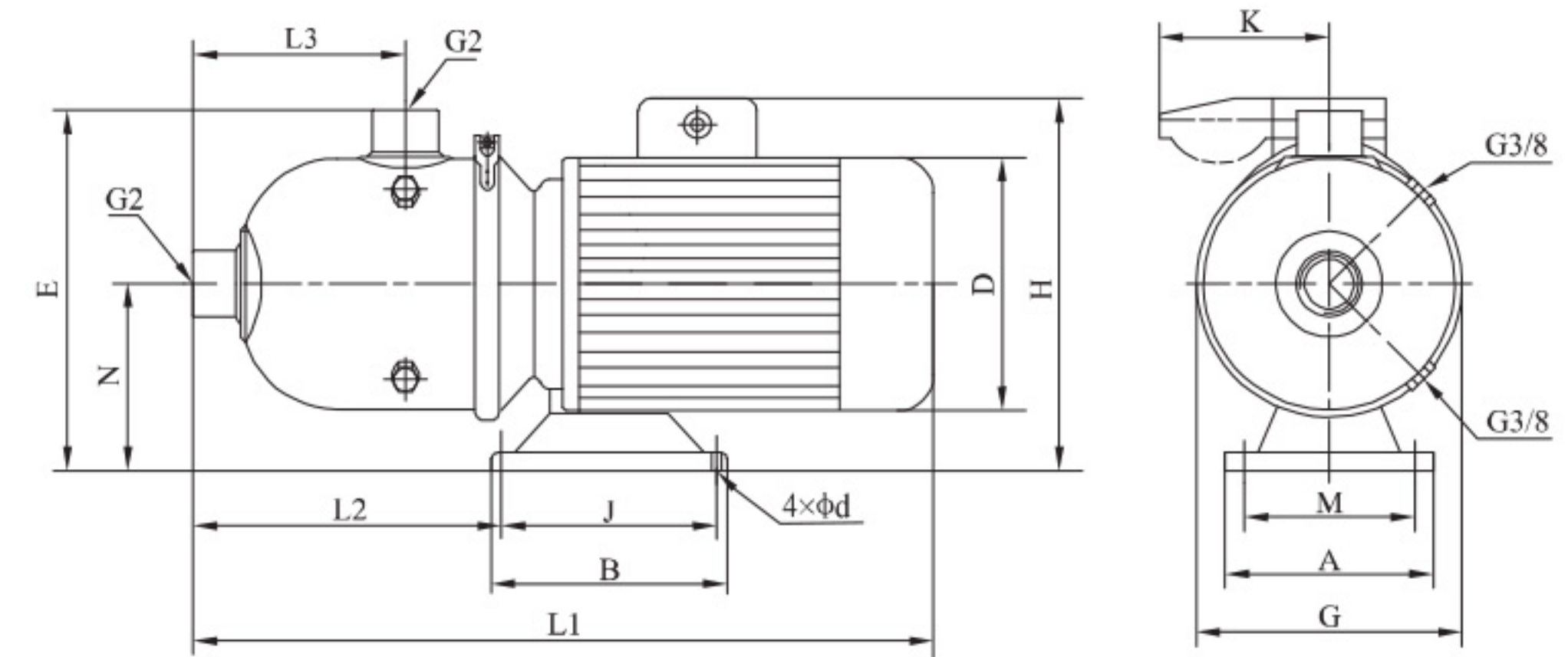

Size and weight

Motor	Model	Size (mm)														Weight (kg)
		L1	L2	L3	N	E	G	A	M	B	J	d	D	H	K	
Three-phase/ single-phase	CHL20-10	530	279	176	117	264	223	130	108	160	138	9	151/161	230/265	/91	20
	CHL20-10G	480	199	95	117	249	193	130	108	160	138	9	151/161	230/265	/91	19
	CHL20-20	563	279	176	118	265	223	130	108	160	138	9	171/176	235/270	/91	26
	CHL20-20G	490	199	95	118	250	193	130	108	160	138	9	171/176	235/270	/91	25
	CHL20-30	612	357	176	120	267	223	220	190	170	140	12	213/	270/		40

Performance curve

ISO9906:2012,3B

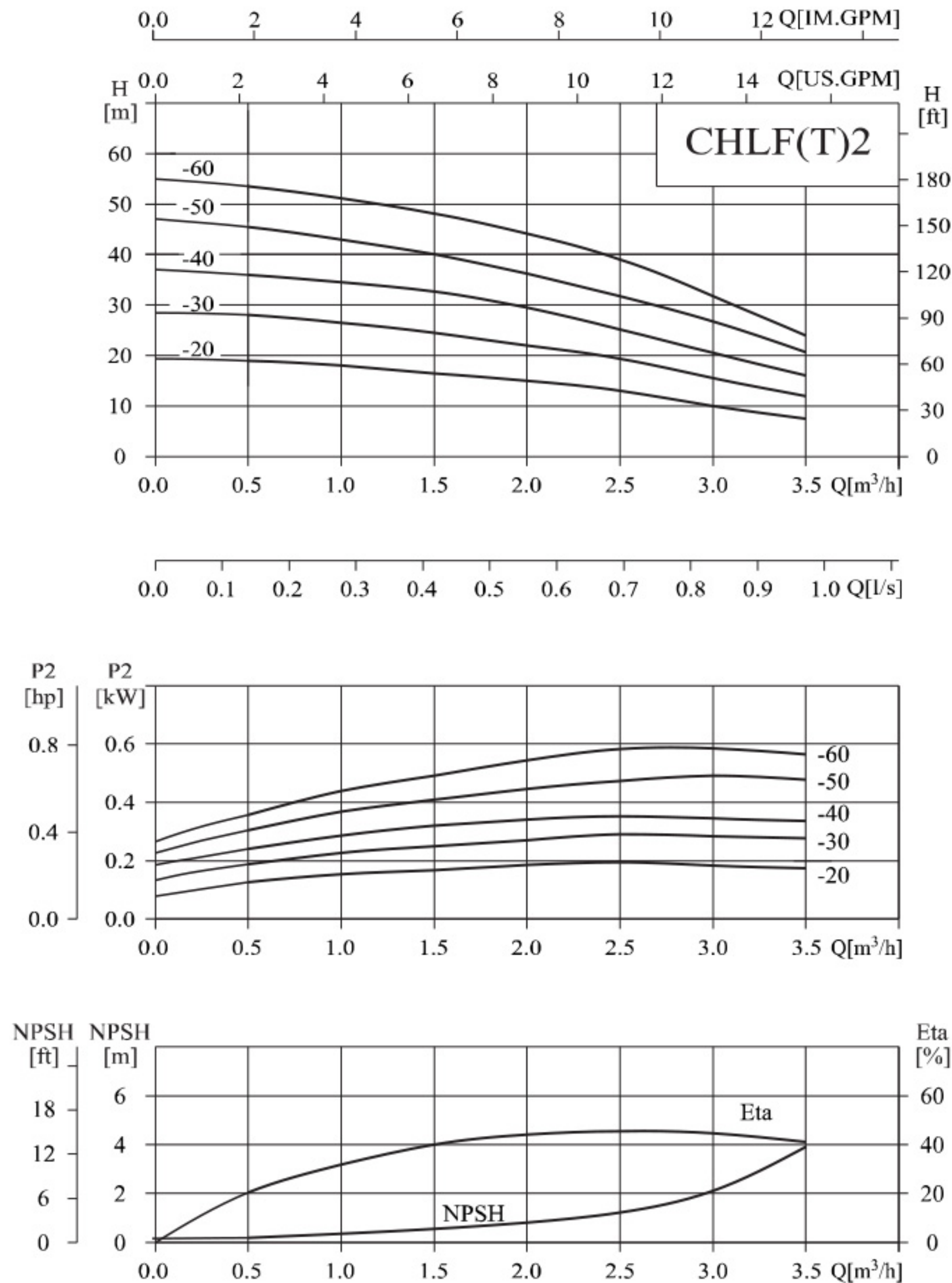

Performance table

Model	Driving motor		Q (m³/h)	0.5	1	1.5	2	2.5	3	3.5
	(kW)	(hp)								
CHLF(T)2-20	0.37	0.5	H (m)	19	18	16.5	15	13	10	7.5
CHLF(T)2-30	0.37	0.5		28	26.5	24.5	22	19	15.5	12
CHLF(T)2-40	0.55	0.75		36	34.5	33	29	25	20.5	16
CHLF(T)2-50	0.55	0.75		45.5	43	40	36	31.5	26.5	20.5
CHLF(T)2-60	0.75	1		53.5	51	48	44	39	32	24

Installation sketch

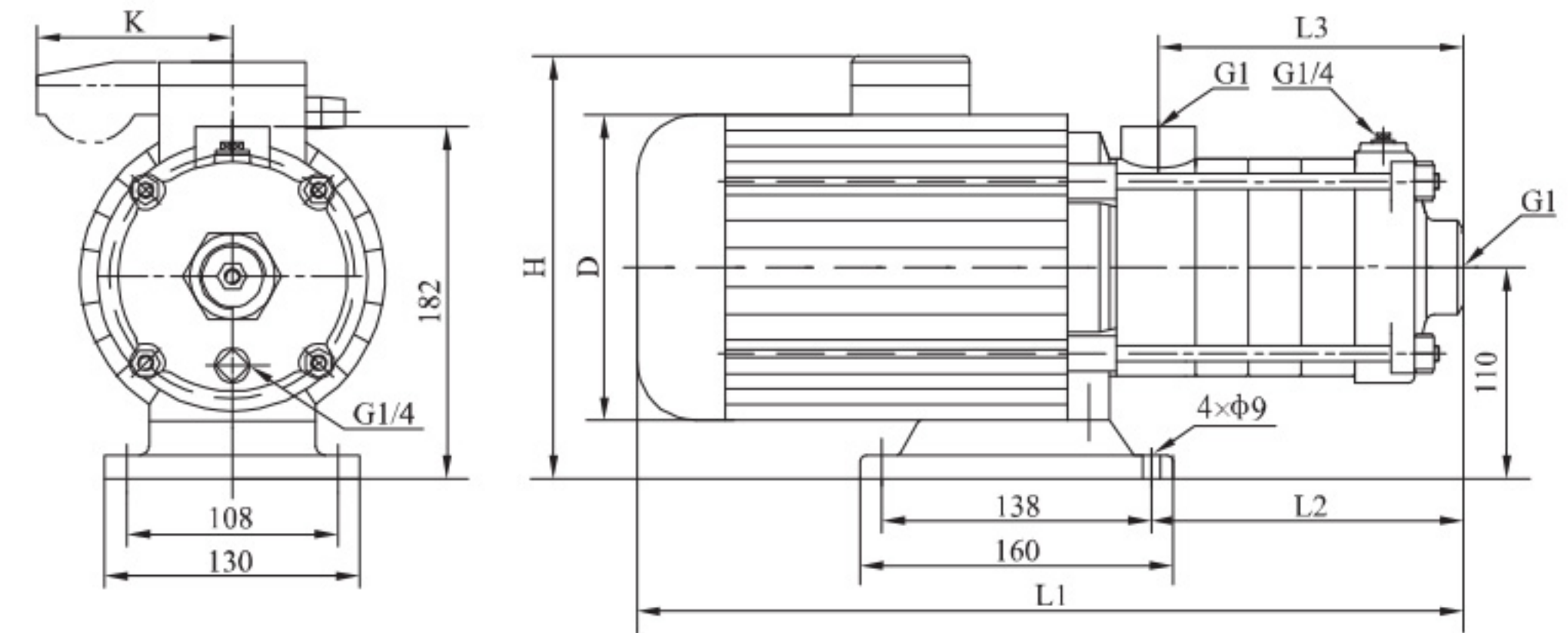

Size and weight

Motor	Model	Size (mm)						Weight (kg)
		L1	L2	L3	D	H	K	
Three-phase/ single-phase	CHLF(T)2-20	305	87	84	141	215/230	/62	9
	CHLF(T)2-30	323	105	102	141	215/230	/62	10
	CHLF(T)2-40	341	123	120	141	215/230	/62	11
	CHLF(T)2-50	359	141	138	141	215/230	/62	12
	CHLF(T)2-60	422	159	156	151/161	225/245	/91	15

Performance curve

ISO9906:2012,3B

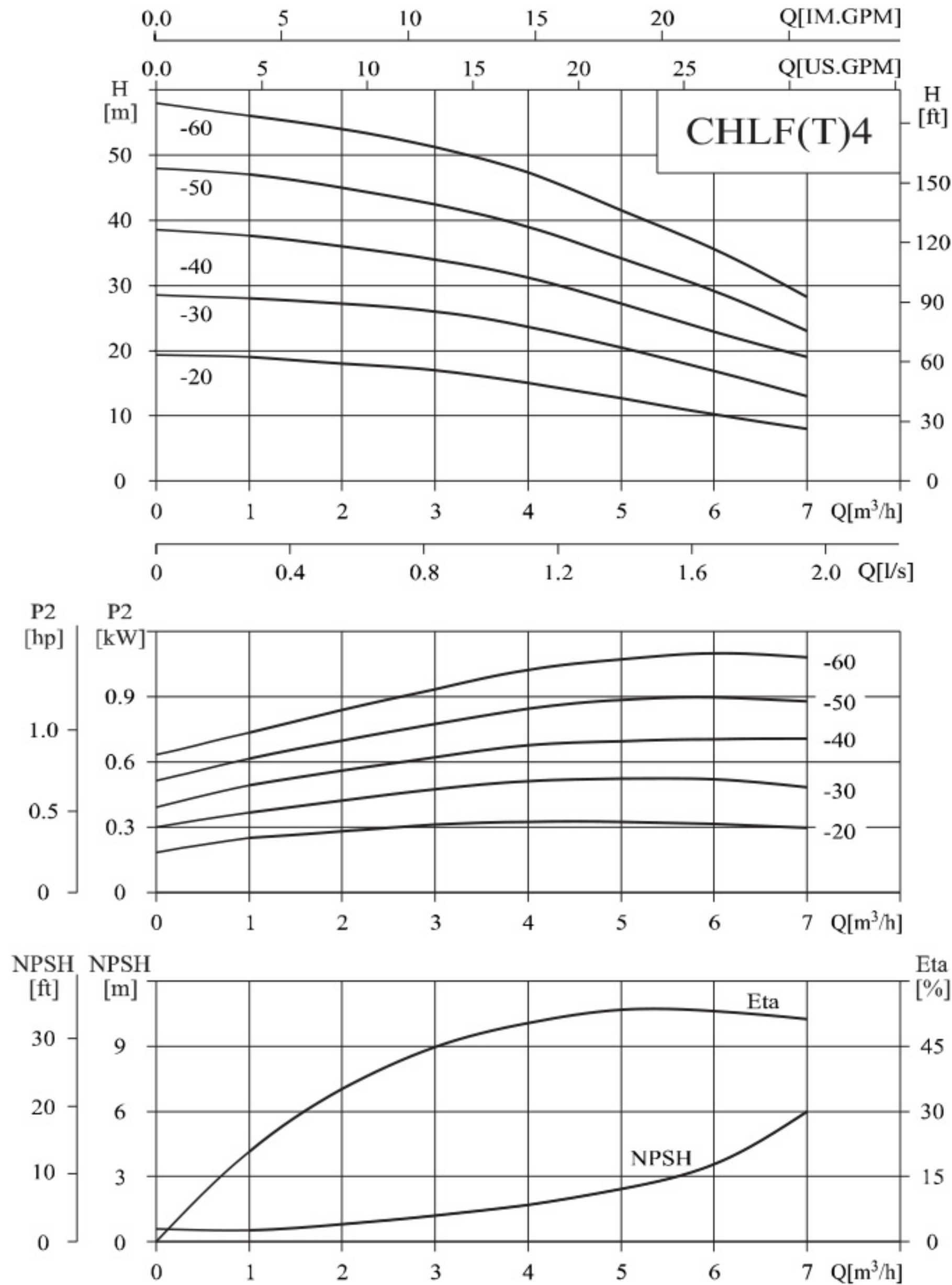

Performance table

Model	Driving motor		Q (m³/h)	1	2	3	4	5	6	7
	(kW)	(hp)								
CHLF(T)4-20	0.37	0.5	H (m)	19	18	17	15	12.5	10	8
CHLF(T)4-30	0.55	0.75		28	27	26	23.5	20.5	17	13
CHLF(T)4-40	0.75	1		37.5	36	34	31	27	23	19
CHLF(T)4-50	1.1	1.5		47	45	42.5	39	34	29	23
CHLF(T)4-60	1.1	1.5		56	54	51	47	41.5	35.5	28

Installation sketch

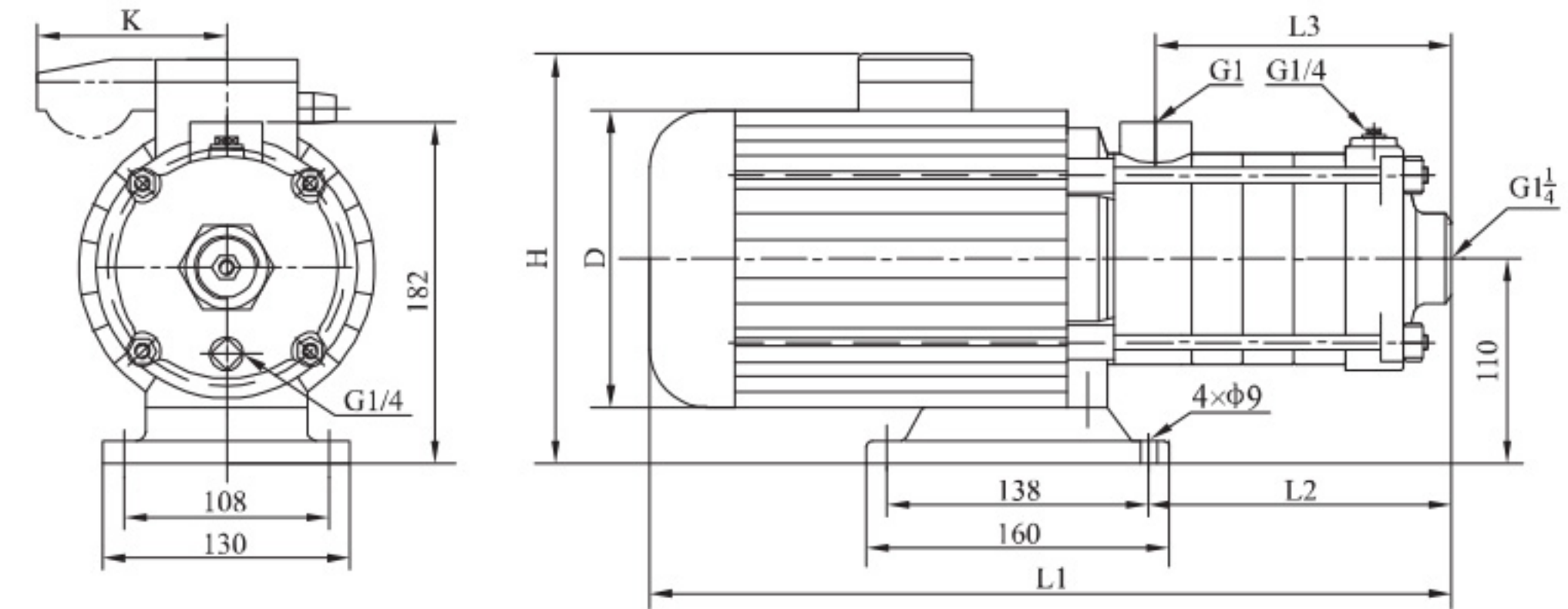

Size and weight

Motor	Model	Size (mm)						Weight (kg)
		L1	L2	L3	D	H	K	
Three-phase/ single-phase	CHLF(T)4-20	329	105	102	141	215/230	/62	10
	CHLF(T)4-30	356	132	129	141	215/230	/62	11
	CHLF(T)4-40	416	162	156	151/161	225/245	/91	14
	CHLF(T)4-50	455	188	183	151/161	225/245	/91	16
	CHLF(T)4-60	482	213	210	151/161	225/245	/91	17

Performance curve

ISO9906:2012,3B

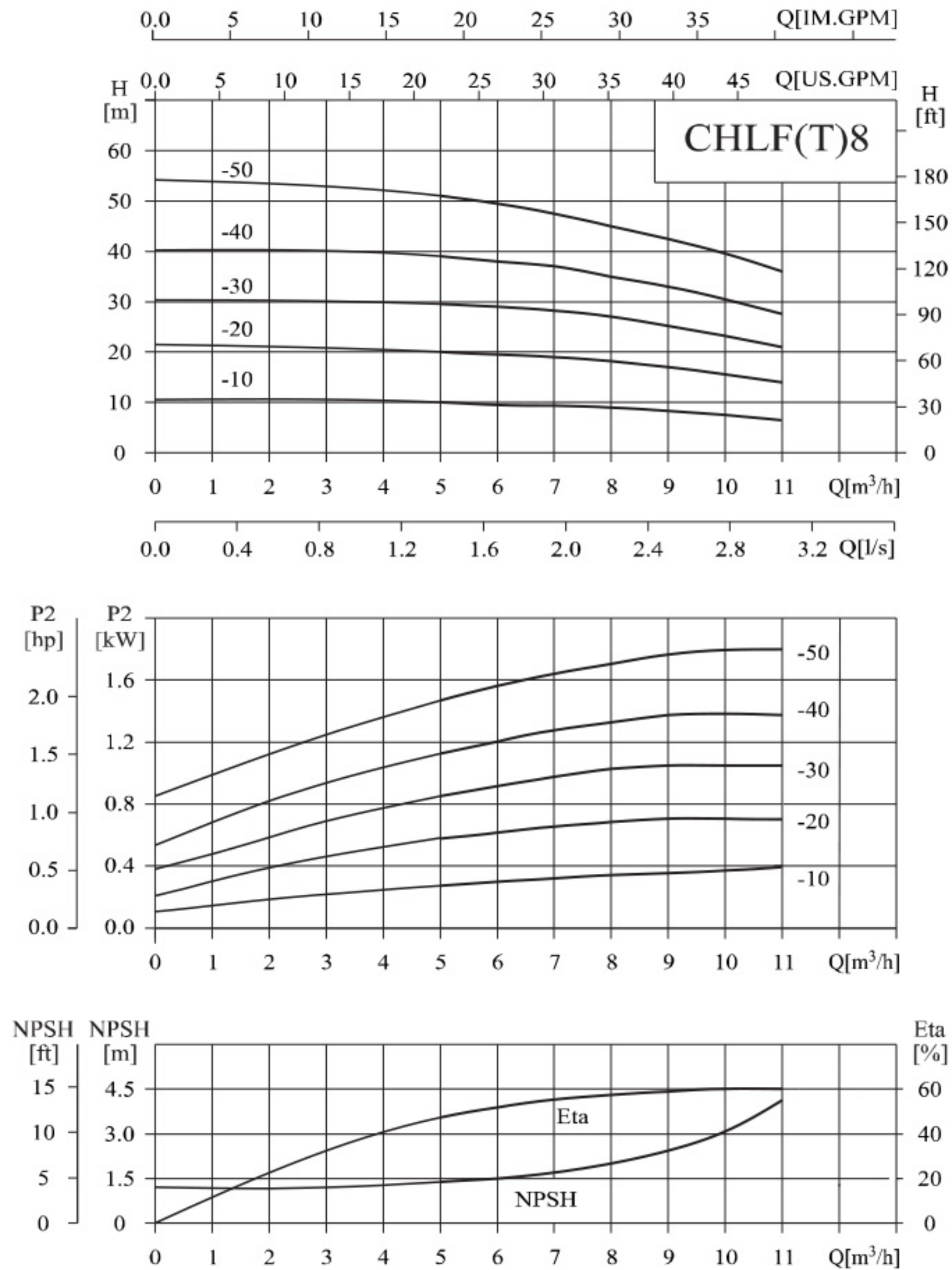

Performance table

Model	Driving motor		Q (m³/h)	5	6	7	8	9	10	11
	(kW)	(hp)								
CHLF(T)8-10	0.75	1	H (m)	10	9.5	9.3	9	8	7.5	7
CHLF(T)8-20	0.75	1		20	19.5	19	18	17	15.5	14
CHLF(T)8-30	1.1	1.5		29.5	29	28	27	25	23	21
CHLF(T)8-40	1.5	2		39	38	37	35	33	30.5	27.5
CHLF(T)8-50	2.2	3		51	49.5	47.5	45	42.5	39.5	36

Installation sketch

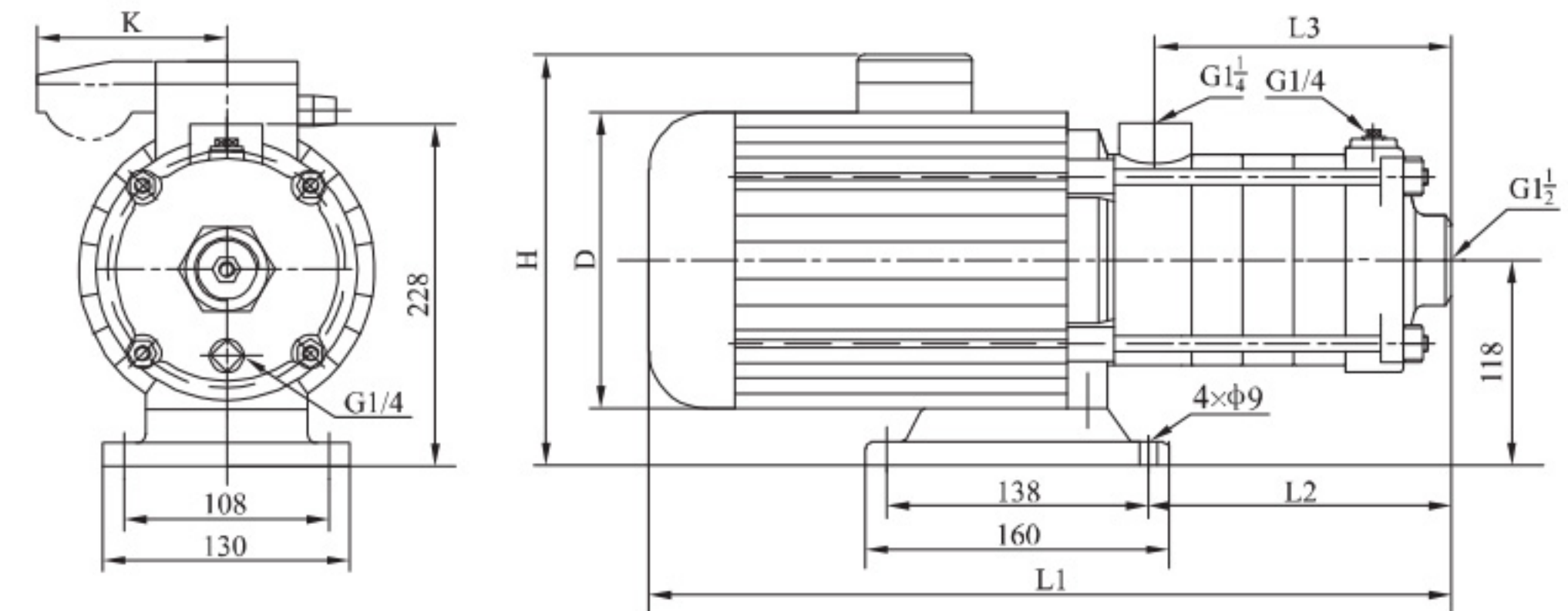

Size and weight

Motor	Model	Size (mm)						Weight (kg)
		L1	L2	L3	D	H	K	
Three-phase/ single-phase	CHLF(T)8-10	395	128	108	151/161	230/265	/91	17
	CHLF(T)8-20	395	128	108	151/161	230/265	/91	17
	CHLF(T)8-30	425	158	138	151/161	230/265	/91	19
	CHLF(T)8-40	490	188	168	171/176	240/270	/91	22
	CHLF(T)8-50	520	218	198	171/176	240/270	/91	25

Performance curve

ISO9906:2012,3B

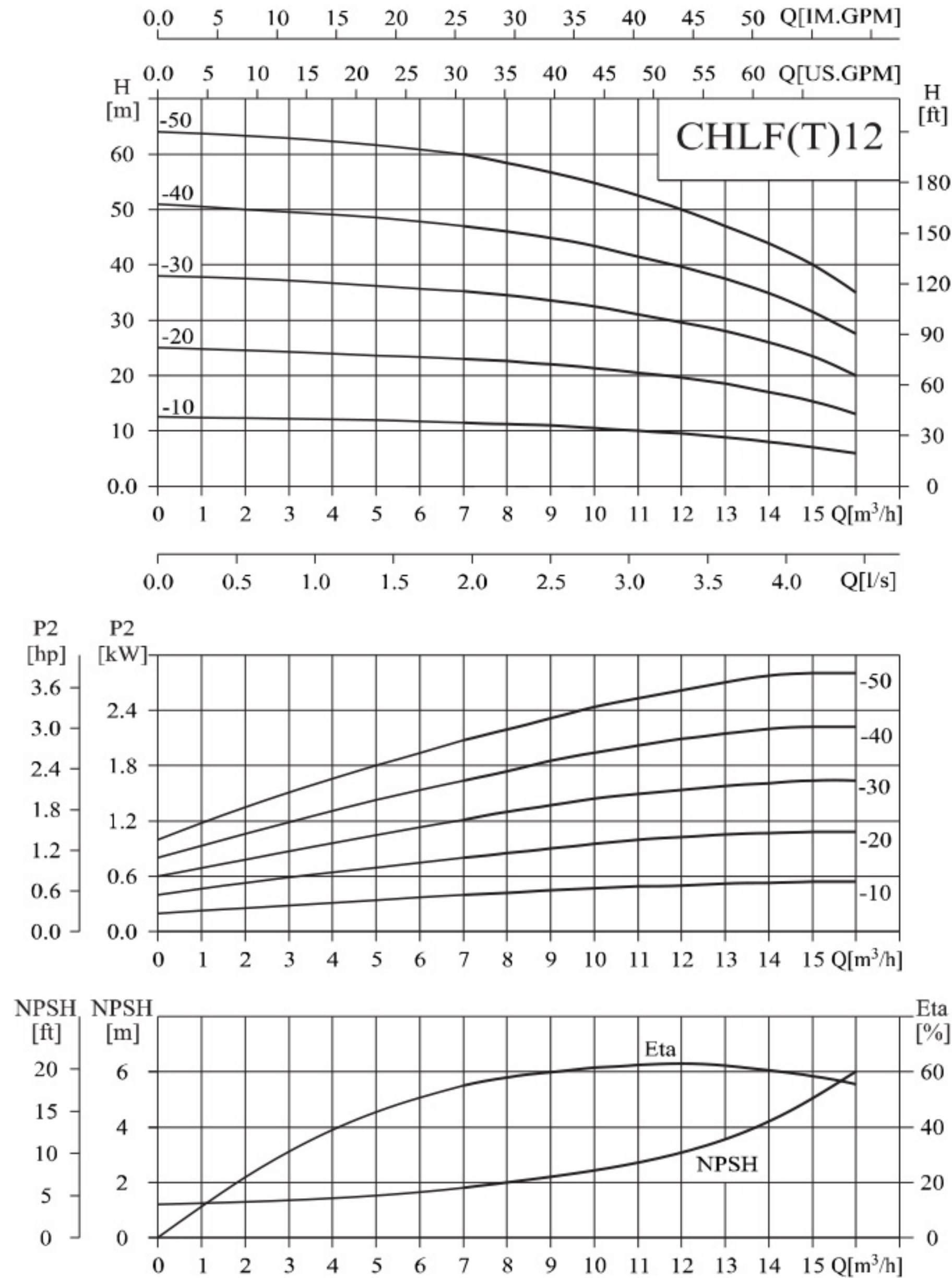

Performance table

Model	Driving motor		Q (m³/h)	7	8	9	10	11	12	13	14	15	16
	(kW)	(hp)		H (m)									
CHLF(T)12-10	0.75	1	H (m)	11.5	11.2	11	10.5	10	9.5	9	8	7	6
CHLF(T)12-20	1.2	1.6		23	22.5	22	21.5	20.5	19.5	18.5	17	15.5	13
CHLF(T)12-30	1.8	2.4		35	34.5	33.5	32.5	31	29.5	28	26	23.5	20
CHLF(T)12-40	2.4	3.3		47	46	45	43.5	41.5	39.5	37.5	35	31.5	27.5
CHLF(T)12-50	3	4		60	58	56.5	55	52.5	50	47	44	40	35

Installation sketch

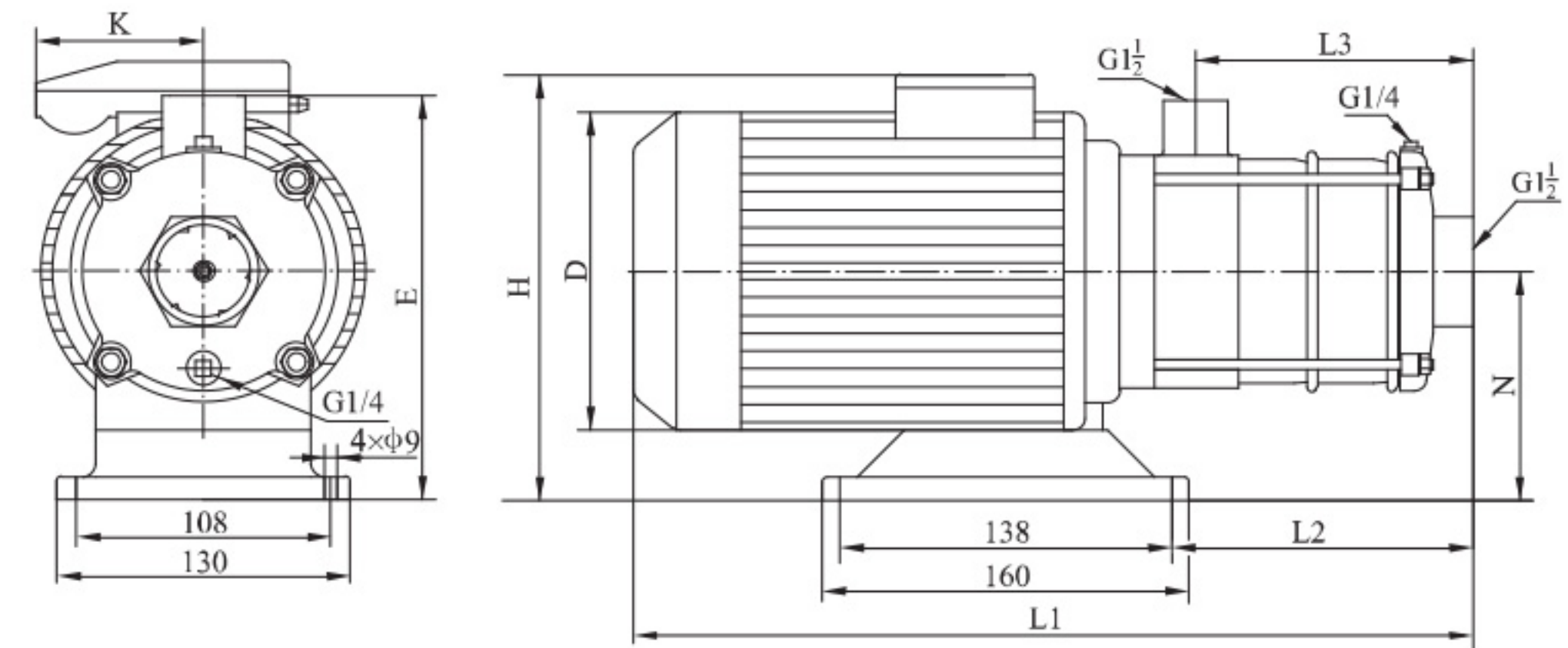

Size and weight

Motor	Model	Size (mm)								Weight (kg)
		L1	L2	L3	H	D	E	N	K	
Three-phase/ single-phase	CHLF(T)12-10	375/375	125	108	230/265	151/161	227	117	/91	18
	CHLF(T)12-20	375/395	125	108	230/265	151/161	227	117	/91	19
	CHLF(T)12-30	445/456	155	138	240/270	171/176	228	118	/91	28
	CHLF(T)12-40	475/486	185	168	240/270	171/176	228	118	/91	30
	CHLF(T)12-50	561/	215	198	259/	197/	238	128		36

Performance curve

ISO9906:2012,3B

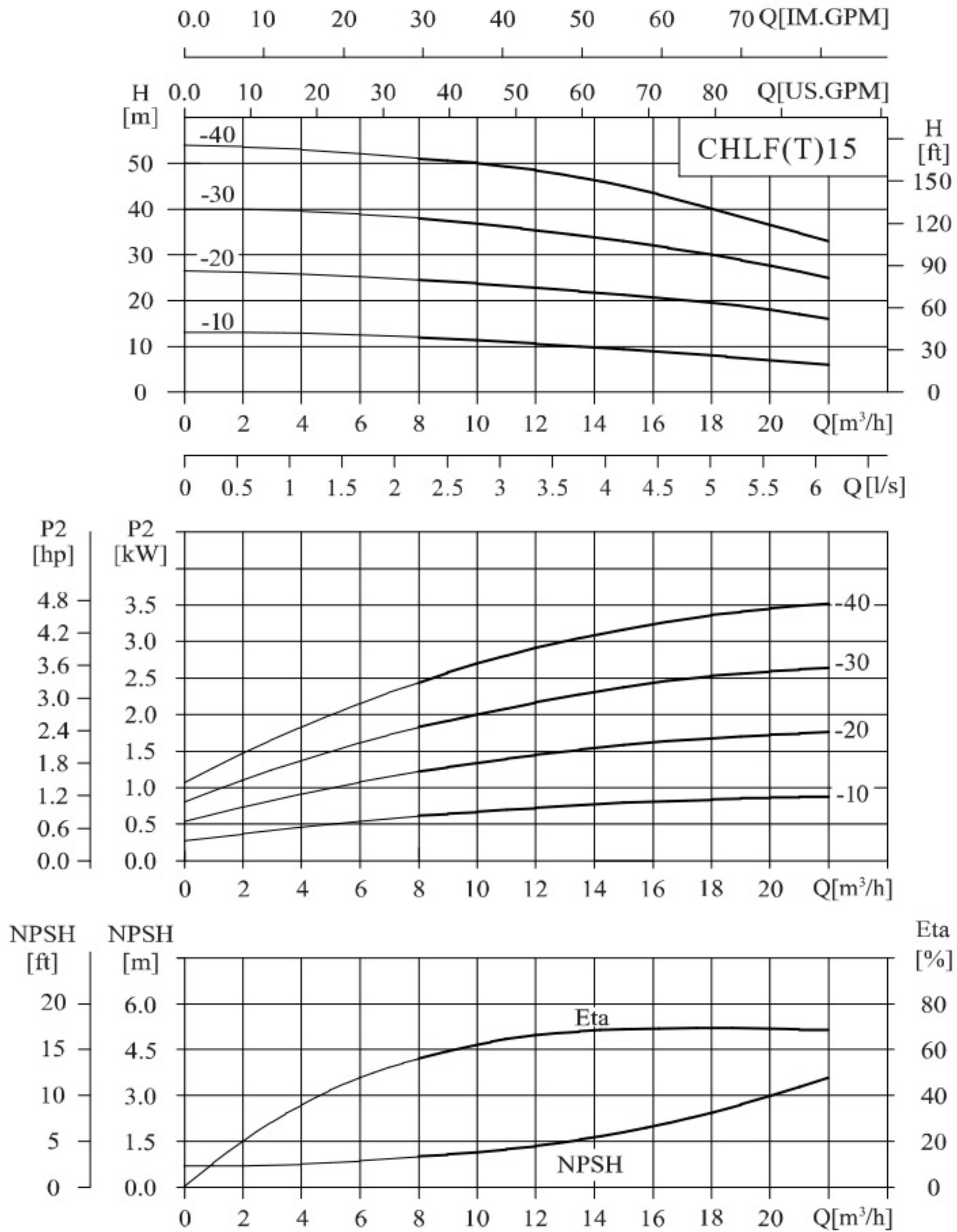

Performance table

Model	Driving motor		Q (m³/h)	8	10	12	14	15	16	18	20	22
	(kW)	(hp)		H (m)								
CHLF(T)15-10	1.1	1.5	H (m)	12	11	10.5	9.5	9	8.5	7.5	6.5	6
CHLF(T)15-20	2.2	3		24.5	24	23	22	21	20.5	19	18	16
CHLF(T)15-30	3	4		38	37	35.5	34	33	32	30	28	25
CHLF(T)15-40	4	5.5		51	50	48	46	45	43	40	37	33

Installation sketch

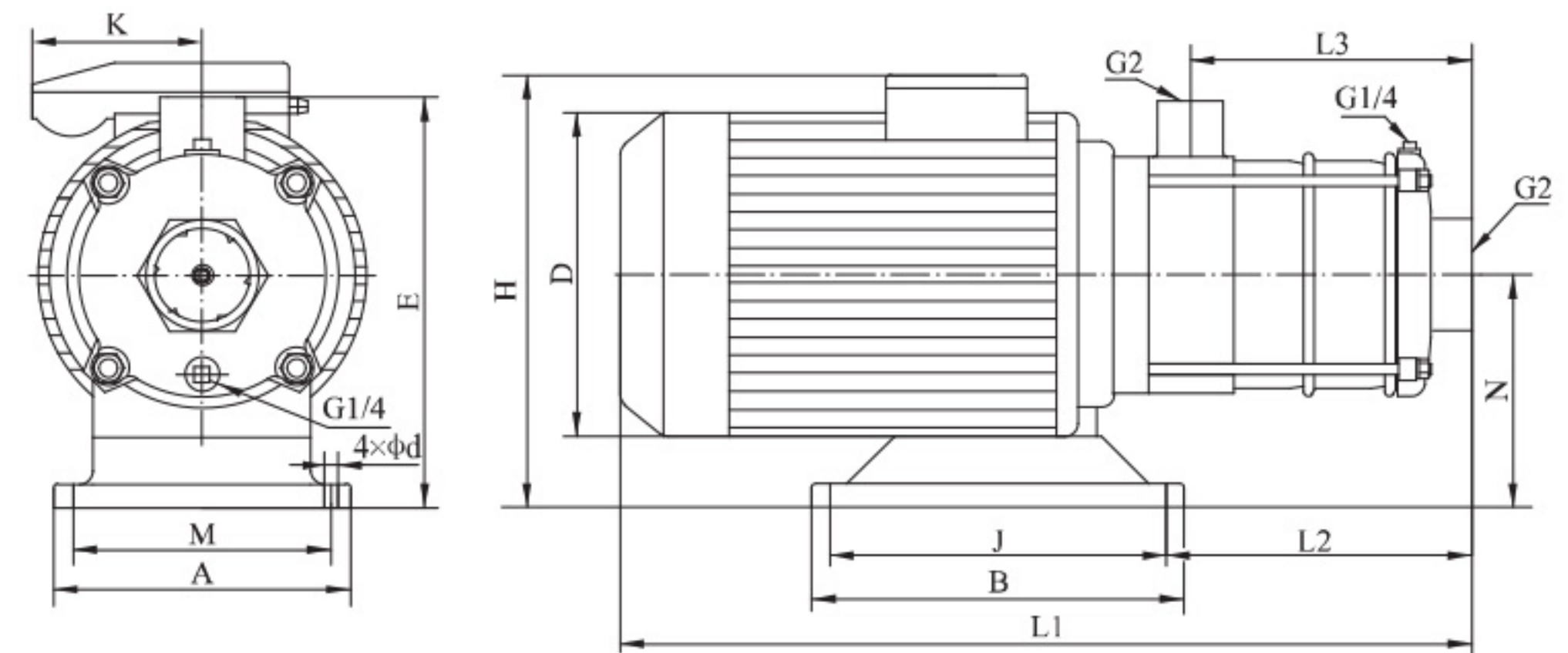

Size and weight

Motor	Model	Size (mm)											Weight (kg)		
		L1	L2	L3	H	D	E	N	A	M	B	J		d	K
Three-phase/ single-phase	CHLF(T)15-10	400/420	150	126	230/265	151/161	227	117	130	108	160	138	9	/91	19
	CHLF(T)15-20	440/451	150	126	240/270	171/176	228	118	130	108	160	138	9	/91	27
	CHLF(T)15-30	544/	195	171	259/	197/	238	128	130	108	160	138	9		34
	CHLF(T)15-40	595/	336	216	270/	213/	230	120	221	190	170	140	12		41

Performance curve

ISO9906:2012,3B

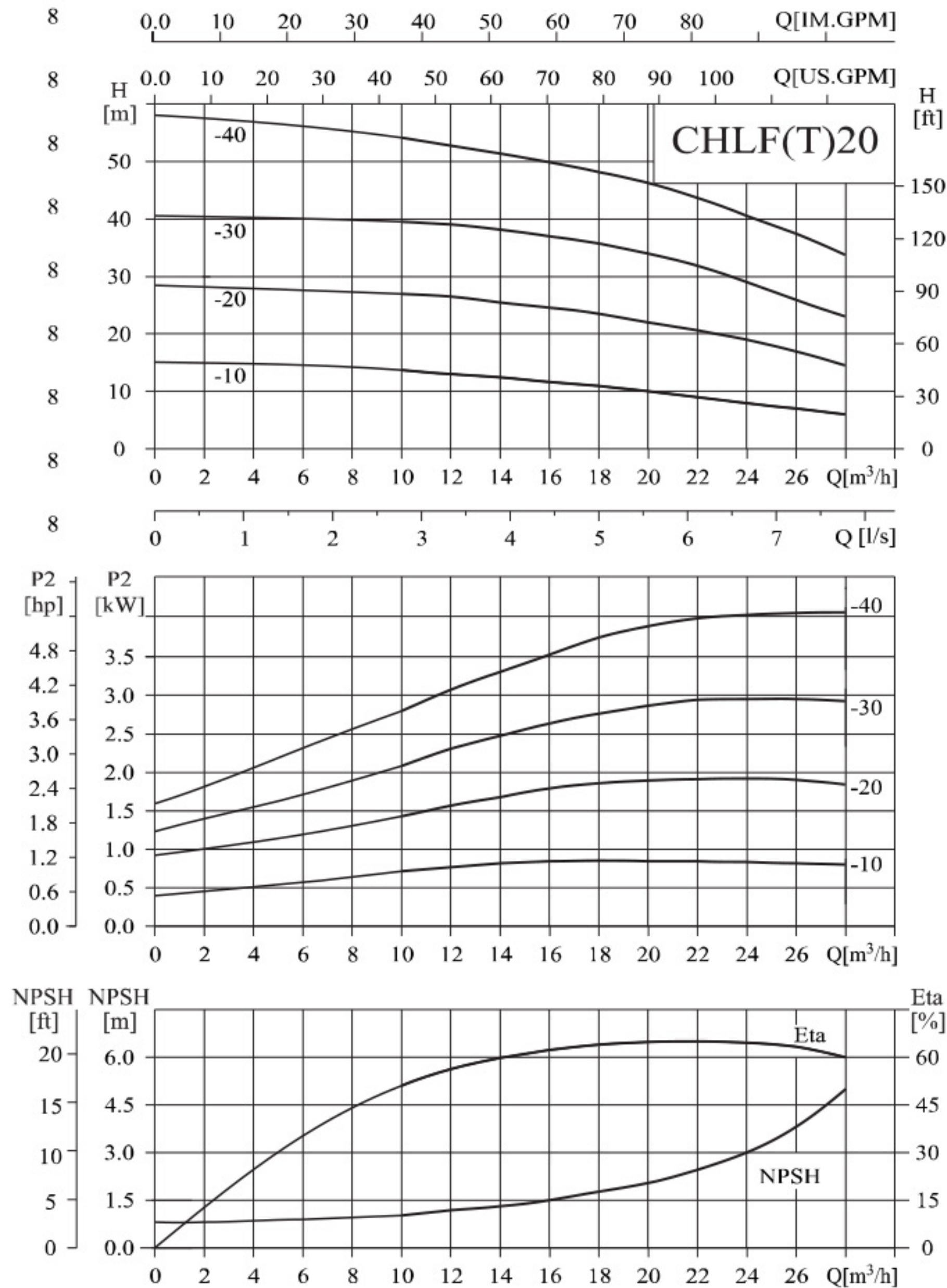

Performance table

Model	Driving motor		Q (m³/h)	10	12	14	16	18	20	22	24	26	28
	(kW)	(hp)											
CHLF(T)20-10	1.1	1.5	H (m)	13.5	13	12.5	12	11	10	9	8	7	6
CHLF(T)20-20	2.2	3		27	26.5	25.5	25	23.5	22	20.5	18.5	17	14.5
CHLF(T)20-30	4	5.5		39.5	39	38	37.5	35.5	34	31.5	29	26	23
CHLF(T)20-40	4.4	6		53	52	51	50	48.5	46.5	43	40	36	32.5

Installation sketch

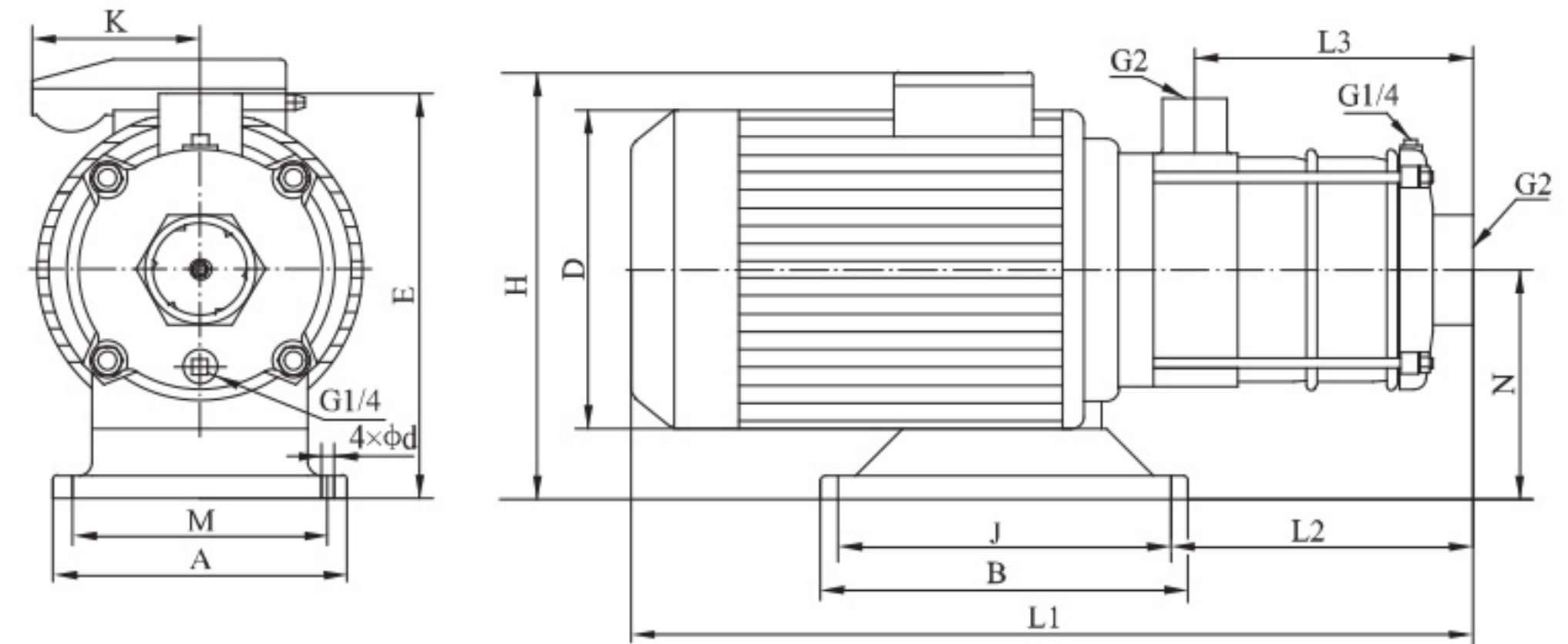

Size and weight

Motor	Model	Size (mm)											Weight (kg)		
		L1	L2	L3	H	D	E	N	A	M	B	J		d	K
Three-phase/ single-phase	CHLF(T)20-10	400/420	150	126	230/265	151/161	227	117	130	108	160	138	9	/91	19
	CHLF(T)20-20	440/451	150	126	240/270	171/176	228	118	130	108	160	138	9	/91	27
	CHLF(T)20-30	547/	291	171	270/	213/	230	120	221	190	170	140	12		40
	CHLF(T)20-40	592/	336	216	270/	213/	230	120	221	190	170	140	12		42

Performance curve

ISO9906:2012,3B

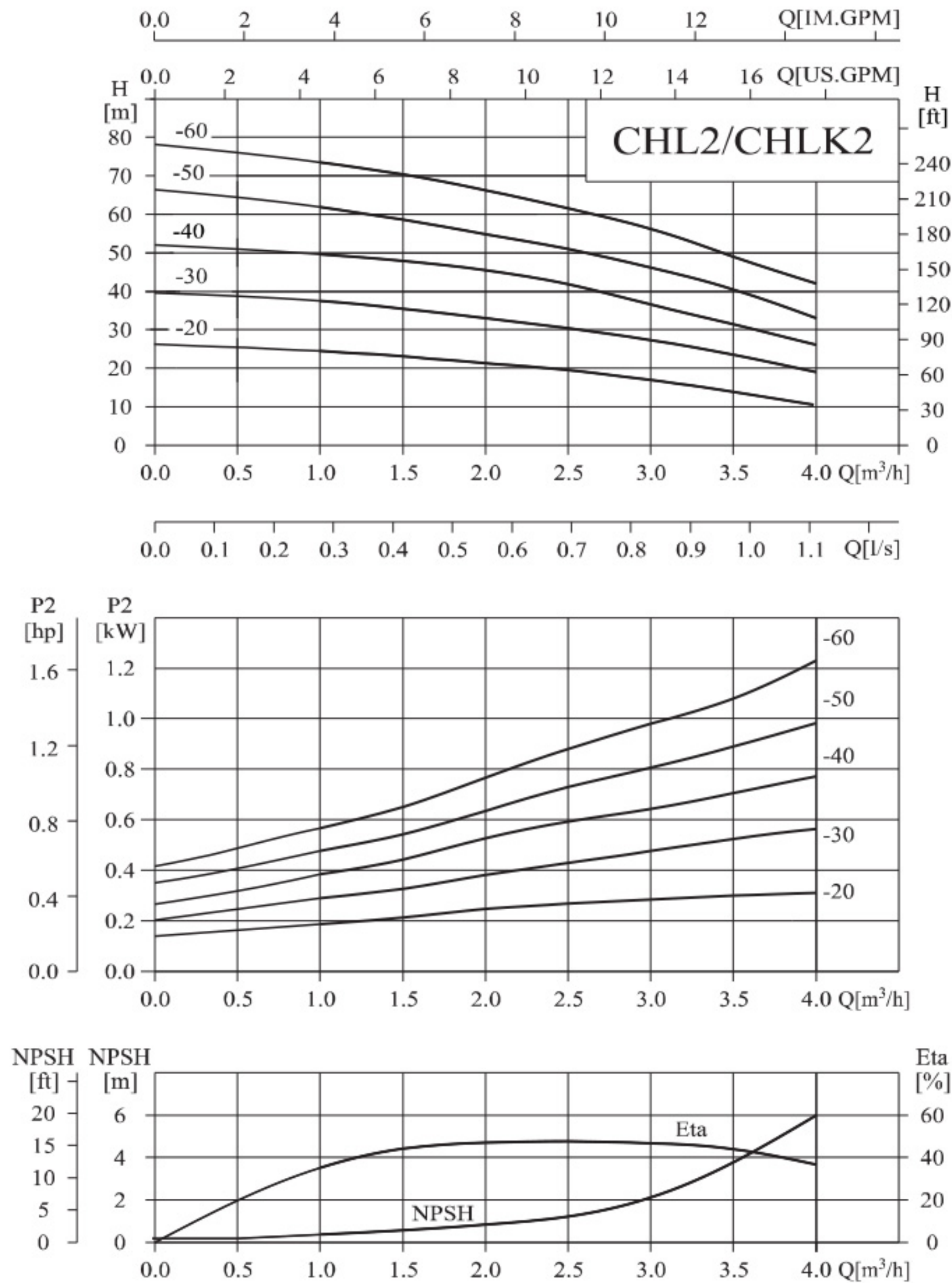

Performance table

Model	Driving motor		Q (m³/h)	1	1.5	2	2.5	3	3.5	4
	(kW)	(hp)								
CHL2-20	0.55	0.75	H (m)	24.5	23	21.5	19.5	17	14	10.5
CHL2-20G	0.55	0.75		24.5	23	21.5	19.5	17	14	10.5
CHL2-30	0.75	1		37.5	35.5	33	30.5	27.5	23.5	19
CHL2-30G	0.75	1		37.5	35.5	33	30.5	27.5	23.5	19
CHL2-40	1.1	1.5		49.5	48	45.5	42	36	32	26
CHL2-40G	1.1	1.5		49.5	48	45.5	42	36	32	26
CHL2-50	1.1	1.5		62	58.5	55	51	46	40.5	33
CHL2-60	1.1	1.5		73.5	70.5	66	61.5	56	49	40

Installation sketch

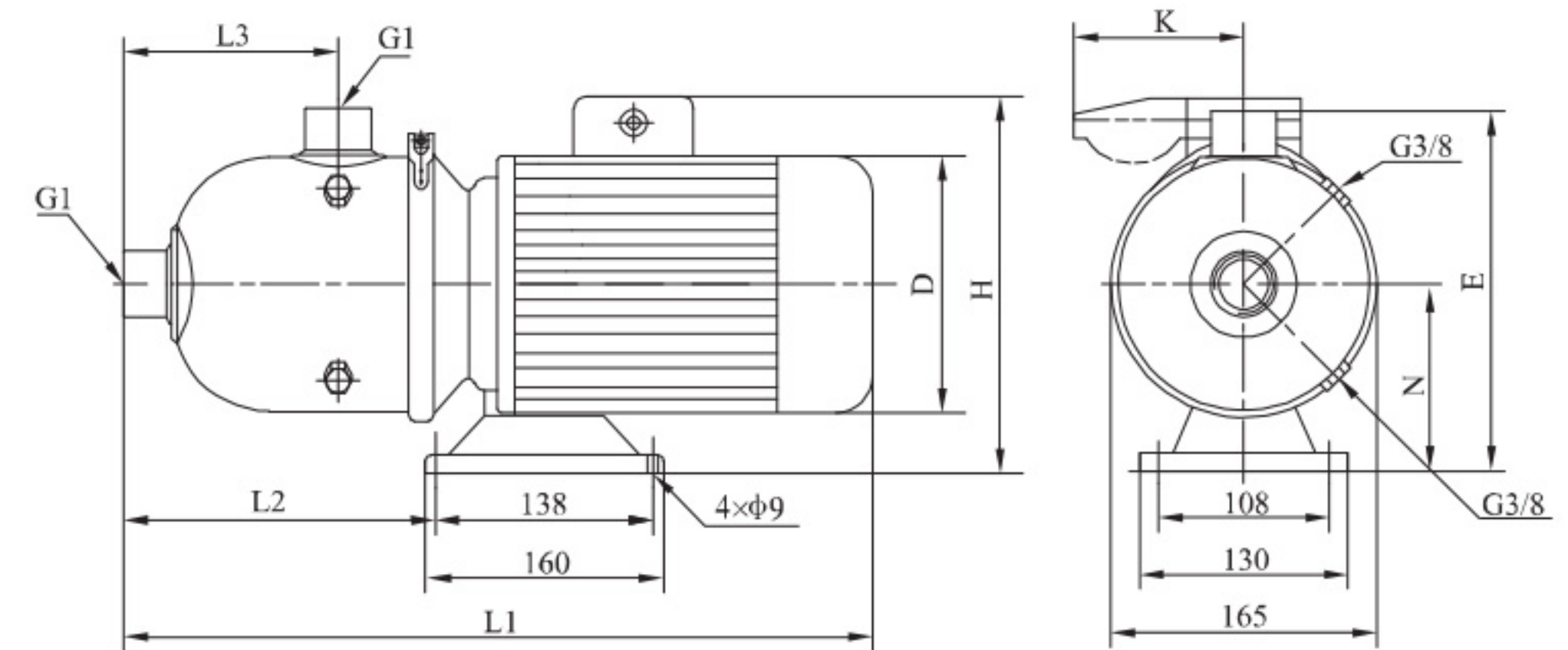

Size and weight

Motor	Model	Size (mm)								Weight (kg)
		L1	L2	L3	H	N	D	E	K	
Three-phase/ single-phase	CHL2-20	400	165	125	215/249	110	141	215	/62	13
	CHL2-20G	360	125	85	215/249	110	141	215	/62	13
	CHL2-30	420	165	125	230/265	110	151/161	215	/91	13
	CHL2-30G	380	125	85	230/265	110	151/161	215	/91	13
	CHL2-40	420	165	125	230/265	110	151/161	215	/91	15
	CHL2-40G	380	125	85	230/265	110	151/161	215	/91	15
	CHL2-50	420	165	125	230/265	110	151/161	215	/91	15
	CHL2-60	420	165	125	230/265	110	151/161	215	/91	15

Performance curve

ISO9906:2012,3B

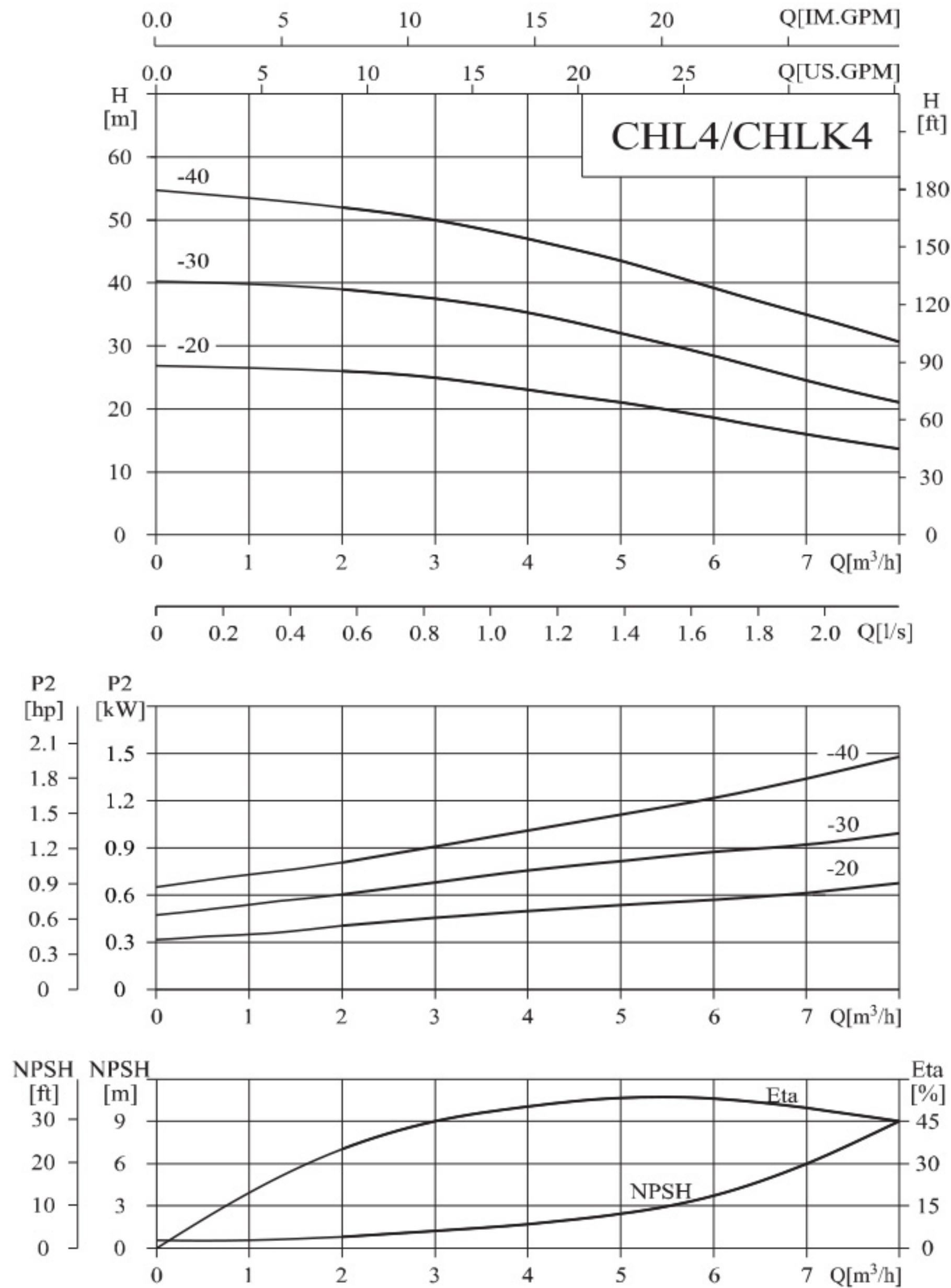

Performance table

Model	Driving motor		Q (m³/h)	2	3	4	5	6	7	8
	(kW)	(hp)								
CHL4-20	0.75	1	H (m)	26	25	23	21	19	16	14
CHL4-20G	0.75	1		26	25	23	21	19	16	14
CHL4-30	1.1	1.5		39	37.5	36	32	28	24	21
CHL4-40	1.5	2		52	50	47	43.5	38.5	35	31

Installation sketch

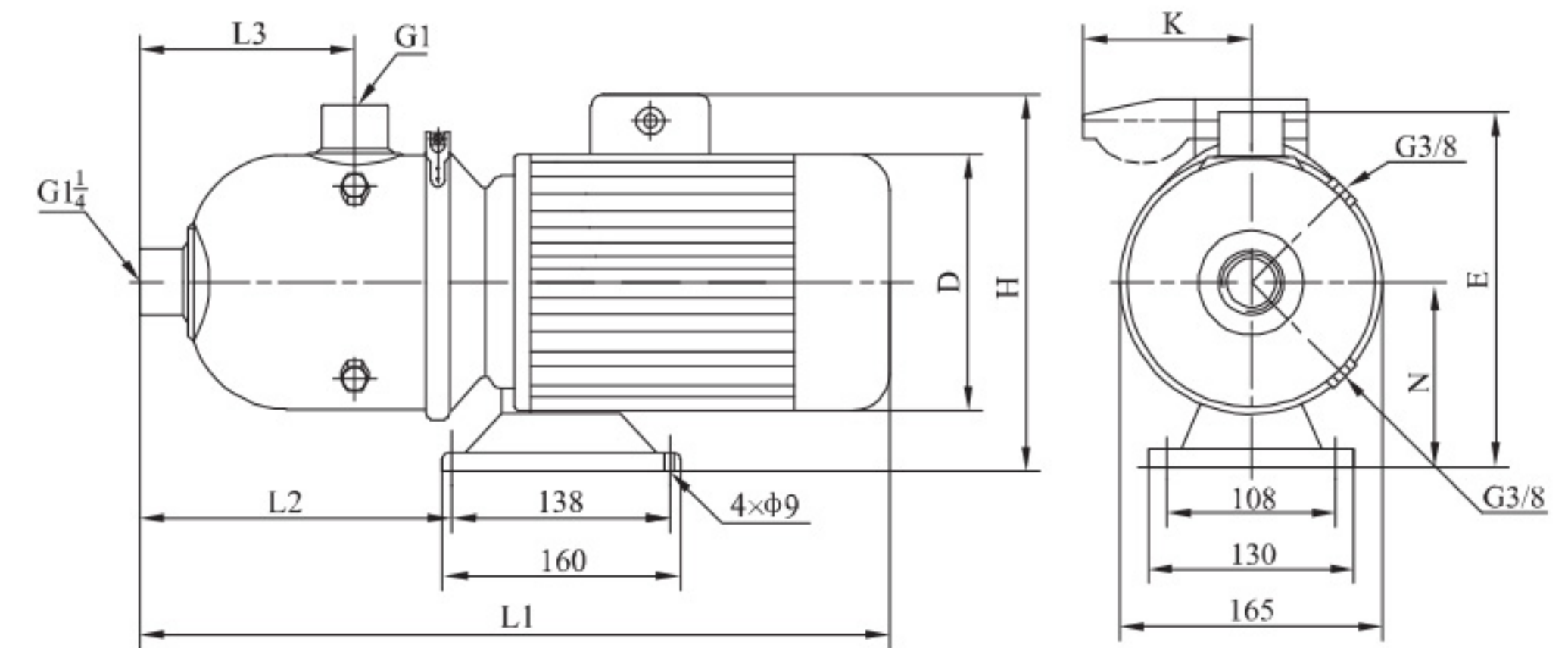

Size and weight

Motor	Model	Size (mm)								Weight (kg)
		L1	L2	L3	H	N	D	E	K	
Three-phase/ single-phase	CHL4-20	420	172	132	230/265	110	151/161	215	/91	12
	CHL4-20G	380	132	92	230/265	110	151/161	215	/91	12
	CHL4-30	420	172	132	230/265	110	151/161	215	/91	15
	CHL4-40	470	172	132	235/270	110	171/176	215	/91	20

Performance curve

ISO9906:2012,3B

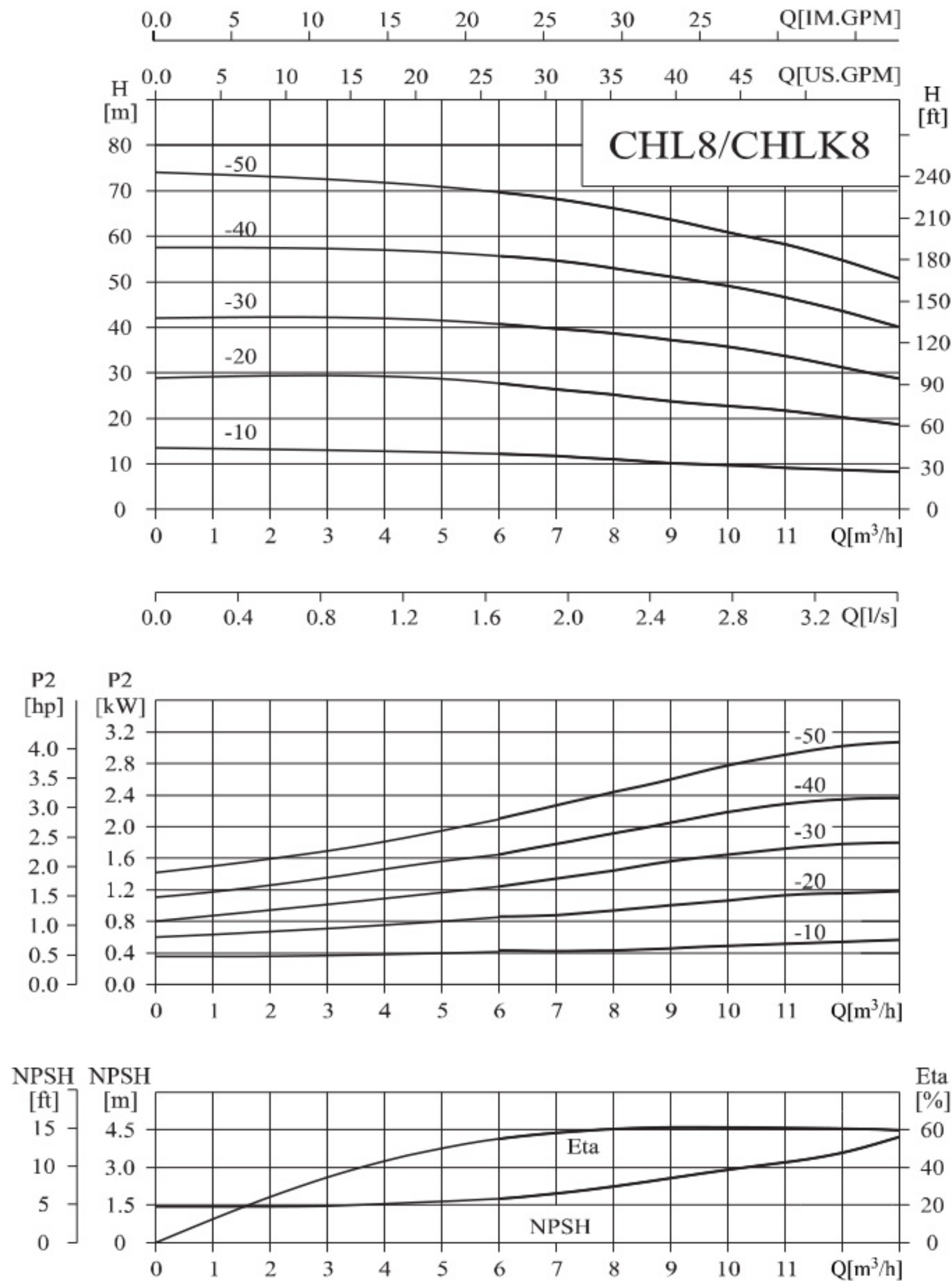

Performance table

Model	Driving motor		Q (m³/h)	6	7	8	9	10	11	12	13
	(kW)	(hp)									
CHL8-10	0.75	1	H (m)	14.5	13	12	11.5	11	10.5	10	9.5
CHL8-10G	0.75	1		14.5	13	12	11.5	11	10.5	10	9.5
CHL8-20	1.5	2		29	27	26	25	24	23	21.5	20
CHL8-20G	1.5	2		29	27	26	25	24	23	21.5	20
CHL8-30	2.2	3		42	41	40	39	37	35	33	30
CHL8-30G	2.2	3		42	41	40	39	37	35	33	30
CHL8-40	3	4		55.5	54.5	53	51	49	46.5	43.5	40
CHL8-50	3	4		71	69.5	67.5	65	63	59	56	52

Installation sketch

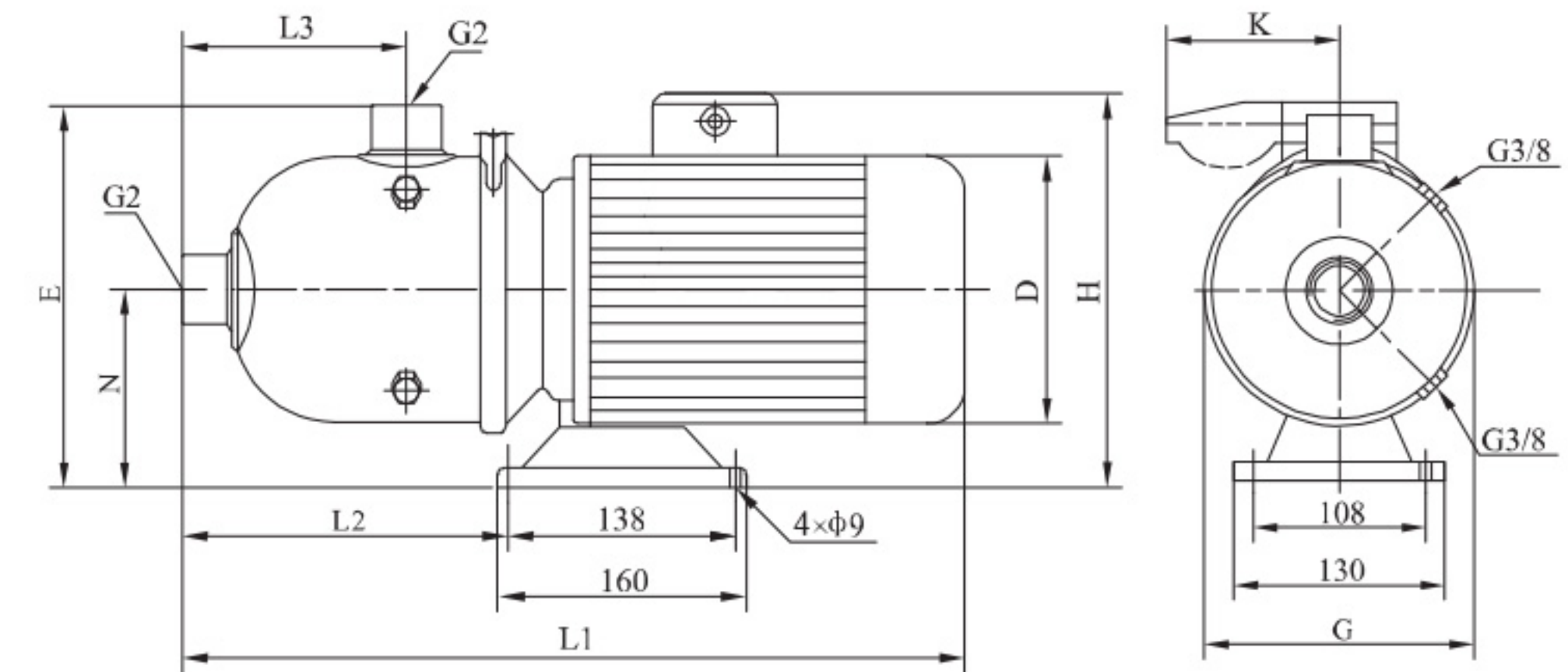

Size and weight

Motor	Model	Size (mm)									Weight (kg)
		L1	L2	L3	N	E	G	D	H	K	
Three-phase/ single-phase	CHL8-10	530	279	176	117	264	223	151/161	230/265	/91	20
	CHL8-10G	480	199	95	117	249	193	151/161	230/265	/91	19.5
	CHL8-20	563	279	176	118	265	223	171/176	235/270	/91	25
	CHL8-20G	490	199	95	118	250	193	171/176	235/270	/91	24.5
	CHL8-30	563	279	176	118	265	223	171/176	235/270	/91	25
	CHL8-30G	490	199	95	118	250	193	171/176	235/270	/91	24.5
	CHL8-40	605	269	176	128	275	223	196/	259/		30
	CHL8-50	605	269	176	128	275	223	196/	259/		30

Performance curve

ISO9906:2012,3B

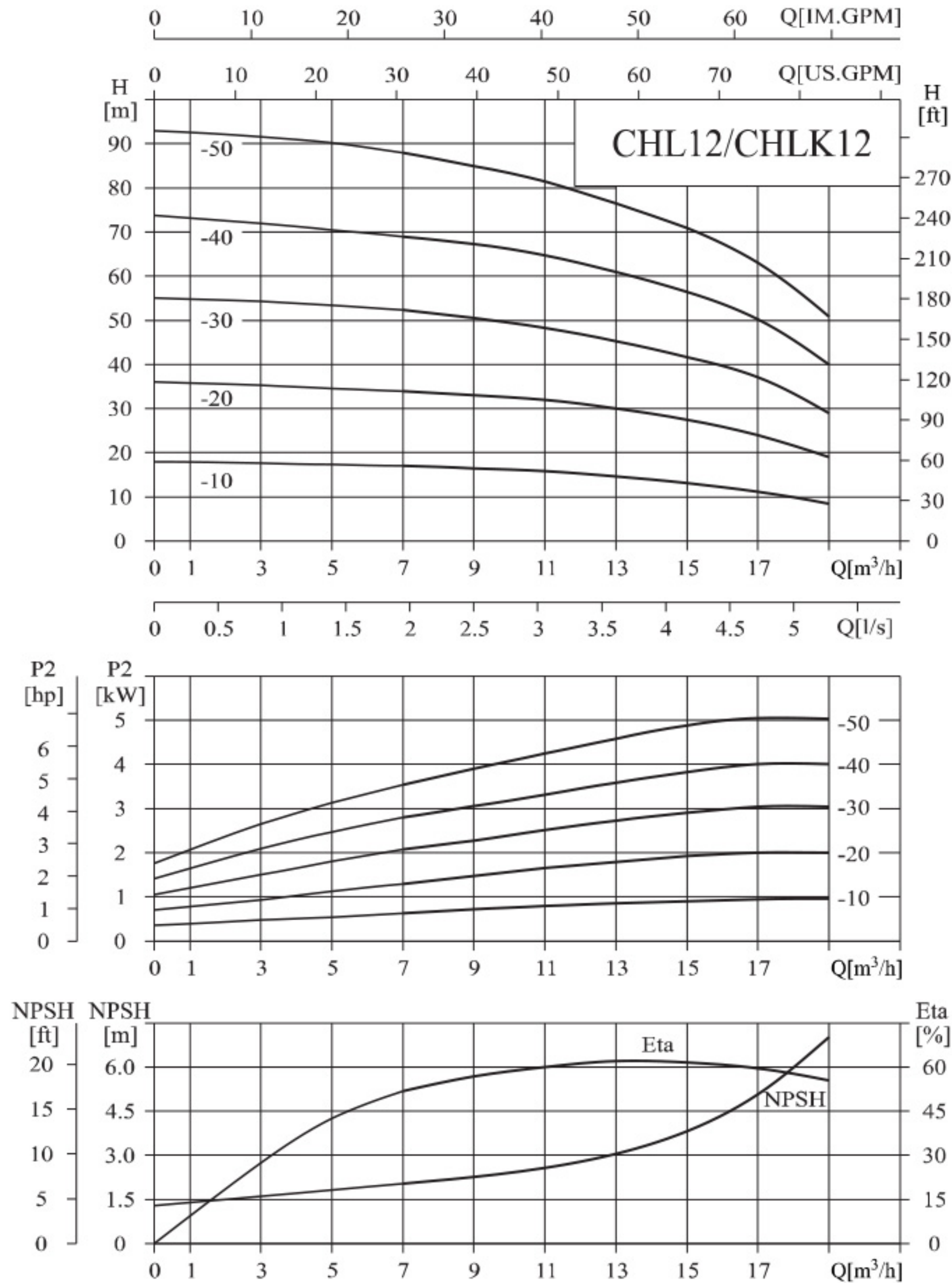

Performance table

Model	Driving motor		Q (m³/h)	7	9	11	12	13	15	17	19
	(kW)	(hp)									
CHL12-10	1.1	1.5	H (m)	17	16	15	14.5	14	12.5	11	8.5
CHL12-10G	1.1	1.5		17	16	15	14.5	14	12.5	11	8.5
CHL12-20	2.2	3		34	33	32	31	30	27	24.5	19
CHL12-20G	2.2	3		34	33	32	31	30	27	24.5	19
CHL12-30	3	4		52.5	50	48.5	47	45	41.5	37.5	29
CHL12-30G	3	4		52.5	50	48.5	47	45	41.5	37.5	29
CHL12-40	4	5.5		69	67.5	65	63	60.5	55	49.5	40
CHL12-50	5.5	7.5		88	85	82	80	76	70	62	50.5

Installation sketch

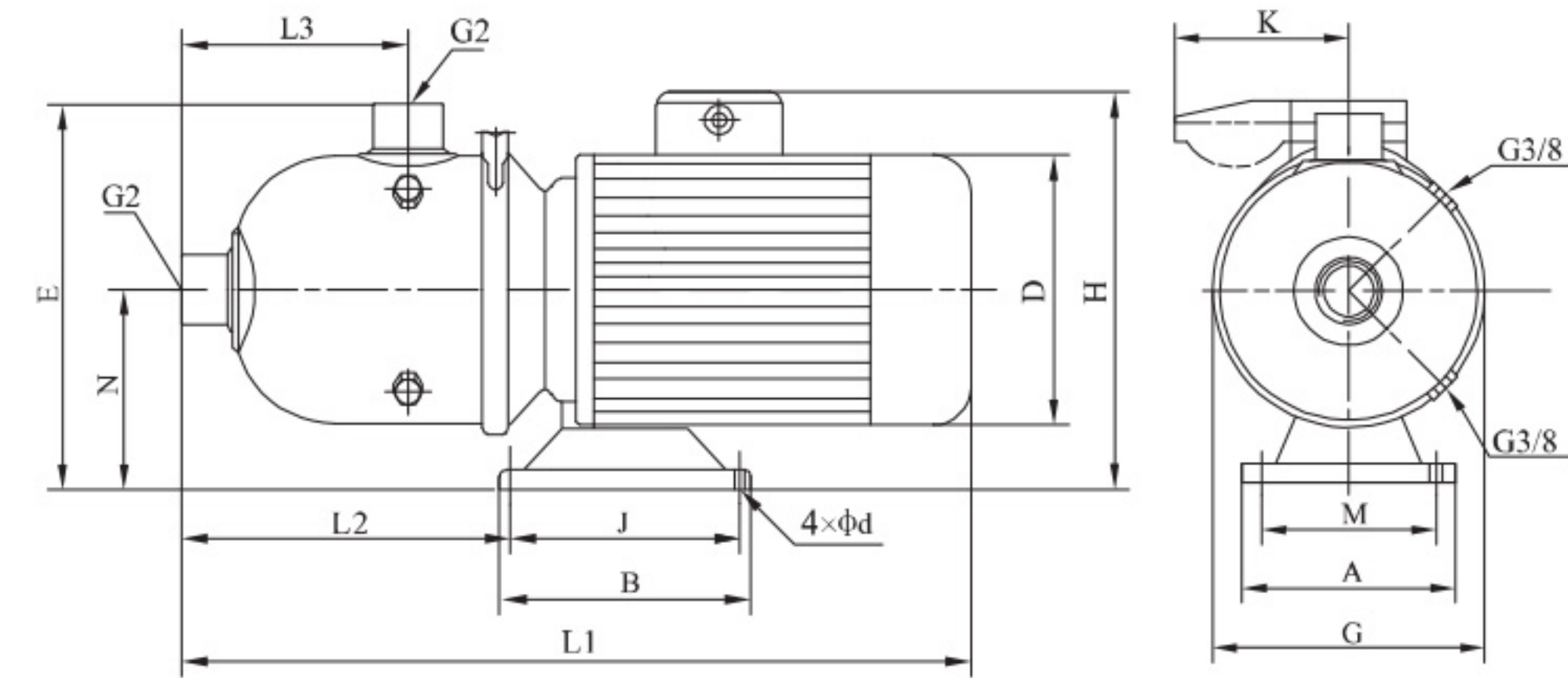

Size and weight

Motor	Model	Size (mm)														Weight (kg)
		L1	L2	L3	N	E	G	A	M	B	J	d	D	H	K	
Three-phase/ single-phase	CHL12-10	530	279	176	117	264	223	130	108	160	138	9	151/161	230/265	/91	22
	CHL12-10G	480	199	95	117	249	193	130	108	160	138	9	151/161	230/265	/91	21.5
	CHL12-20	563	279	176	118	265	223	130	108	160	138	9	171/176	235/270	/91	25
	CHL12-20G	490	199	95	118	250	193	130	108	160	138	9	171/176	235/270	/91	24.5
	CHL12-30	612	279	176	118	265	223	130	108	160	138	9	196/	259/		32
	CHL12-30G	530	199	95	118	250	193	130	108	160	138	9	196/	259/		31.5
	CHL12-40	612	357	176	120	267	223	220	190	170	140	12	213/	270/		44
	CHL12-50	661	369	176	132	279	223	248	216	190	140	12	255/	300/		58

Performance curve

ISO9906:2012,3B

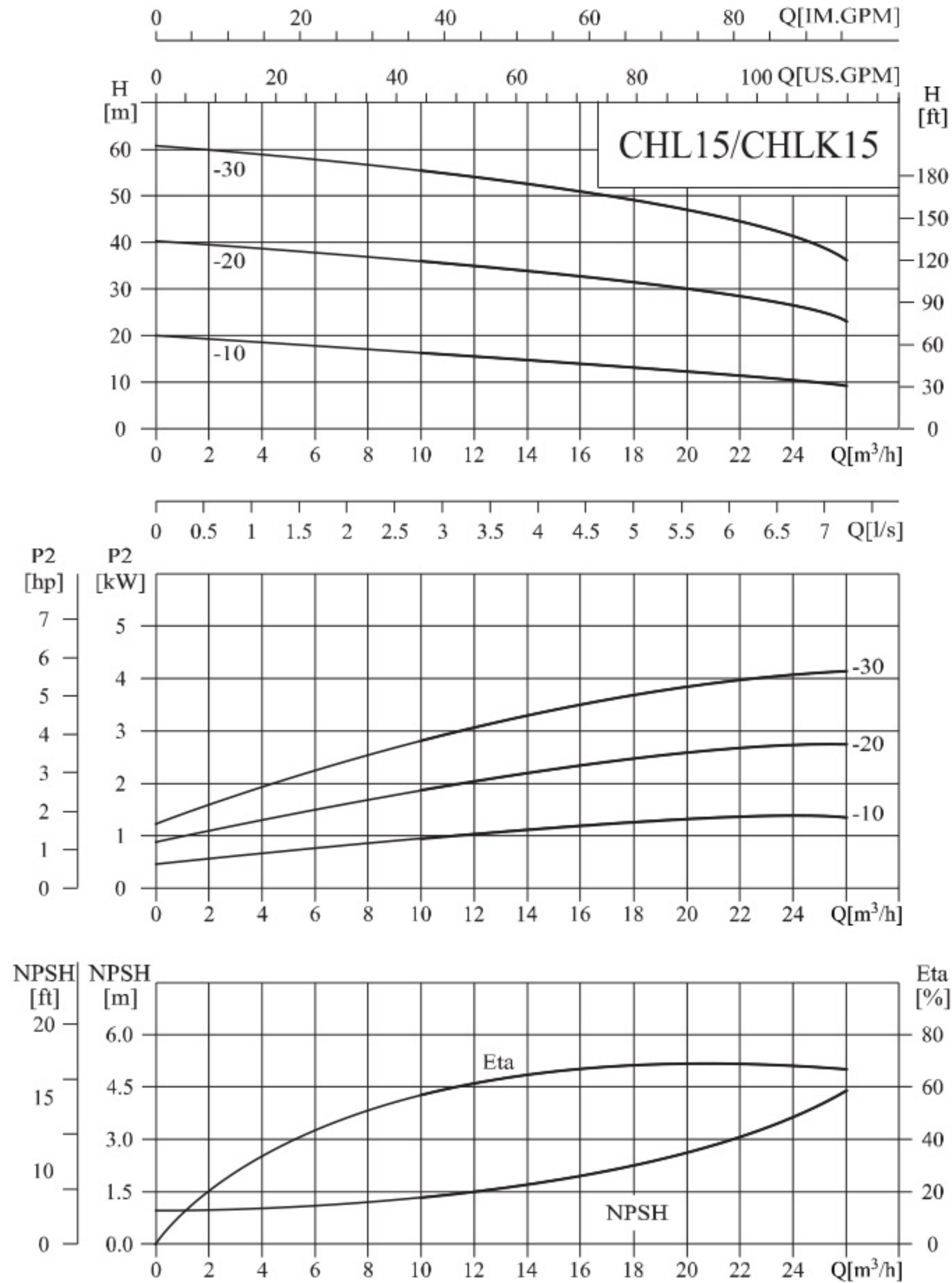

Performance table

Model	Driving motor		Q (m³/h)	10	12	14	15	16	18	20	22	24	26
	(kW)	(hp)		H (m)									
CHL15-10	1.5	2	H (m)	17	15.5	14.5	14	13.5	13	12	11	10	9
CHL15-20	3	4		35.5	34.5	33.5	33	32.5	31	30	28	26	23
CHL15-30	4	5.5		55	53.5	52.5	51.5	51	49	47	44	41	36.5

Installation sketch

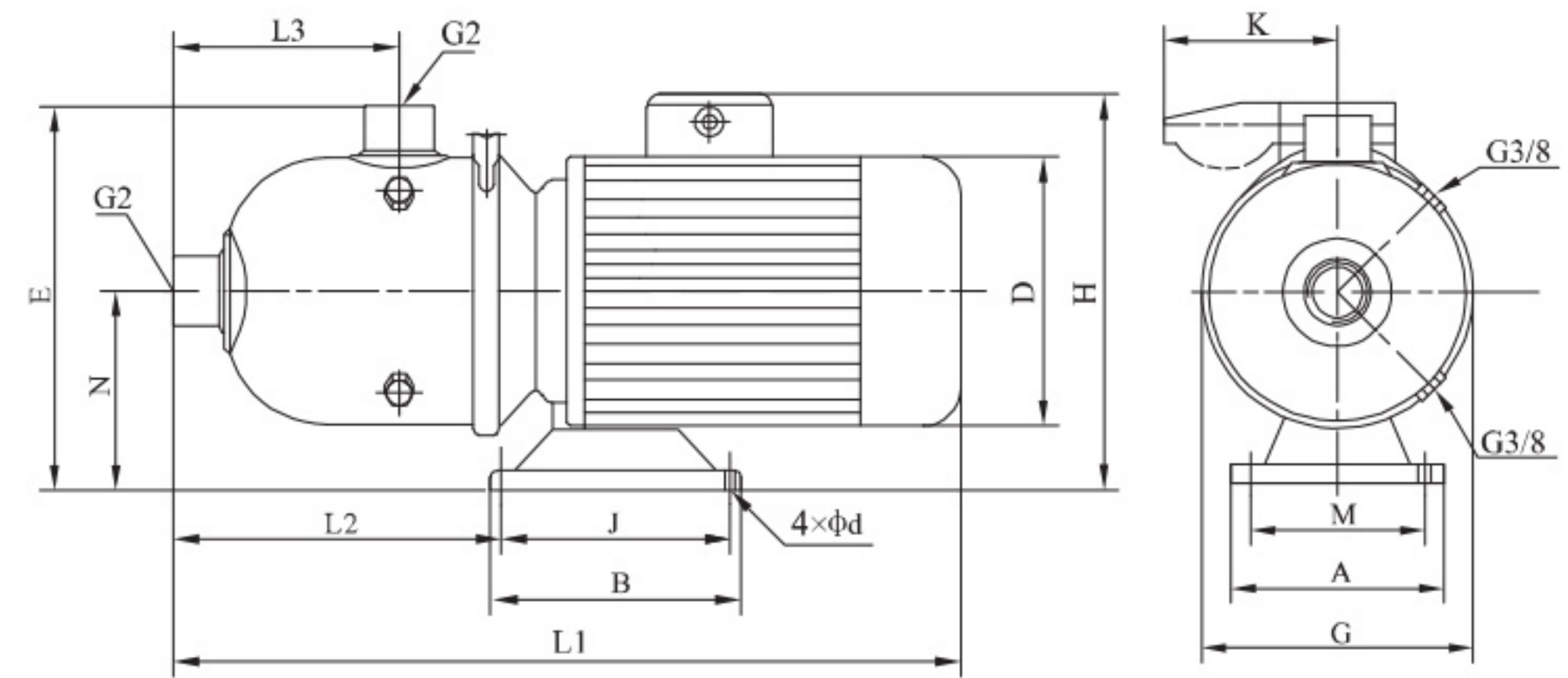

Size and weight

Motor	Model	Size (mm)														Weight (kg)
		L1	L2	L3	N	E	G	A	M	B	J	d	D	H	K	
Three-phase/ single-phase	CHL15-10	563	279	176	118	264	223	130	108	160	138	9	171/176	235/270	/91	23
	CHL15-20	605	279	176	128	274	223	130	108	160	138	9	196/	259/		32
	CHL15-30	612	357	176	120	266	223	220	190	170	140	12	213/	270/		45

Performance curve

ISO9906:2012,3B

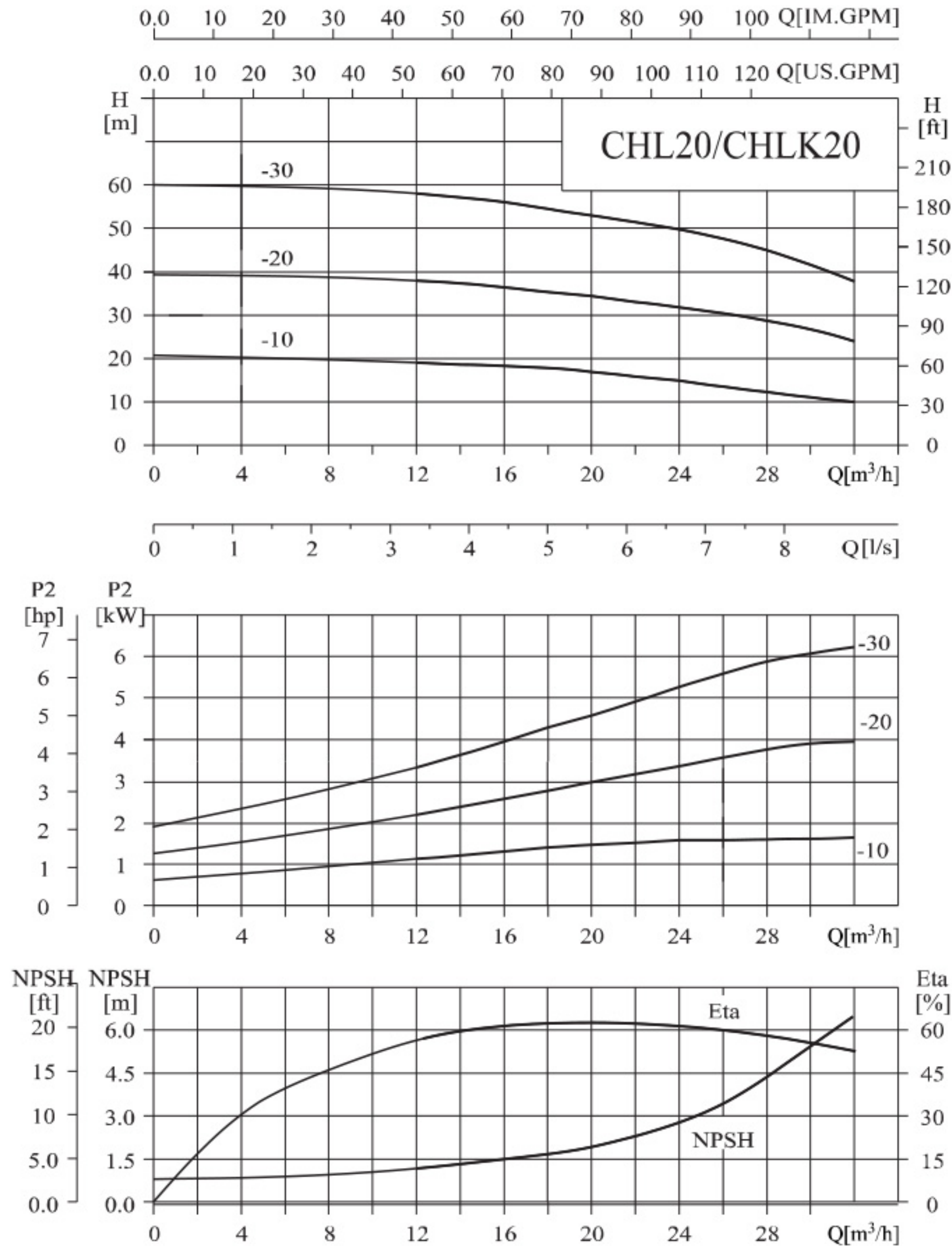

Performance table

Model	Driving motor		Q (m³/h)	12	14	16	18	20	22	24	26	28	30	32
	(kW)	(hp)		H (m)										
CHL20-10	2.2	3	H (m)	19	18.5	18	17.5	17	16	15	13.5	12	11	10
CHL20-10G	2.2	3		19	18.5	18	17.5	17	16	15	13.5	12	11	10
CHL20-20	4	5.5		38	37	36	35	34	33	32	30.5	29	26.5	24
CHL20-20G	4	5.5		38	37	36	35	34	33	32	30.5	29	26.5	24
CHL20-30	5.5	7.5		58	57	56	55	53	51.4	50	47.5	45	41.6	38

Installation sketch

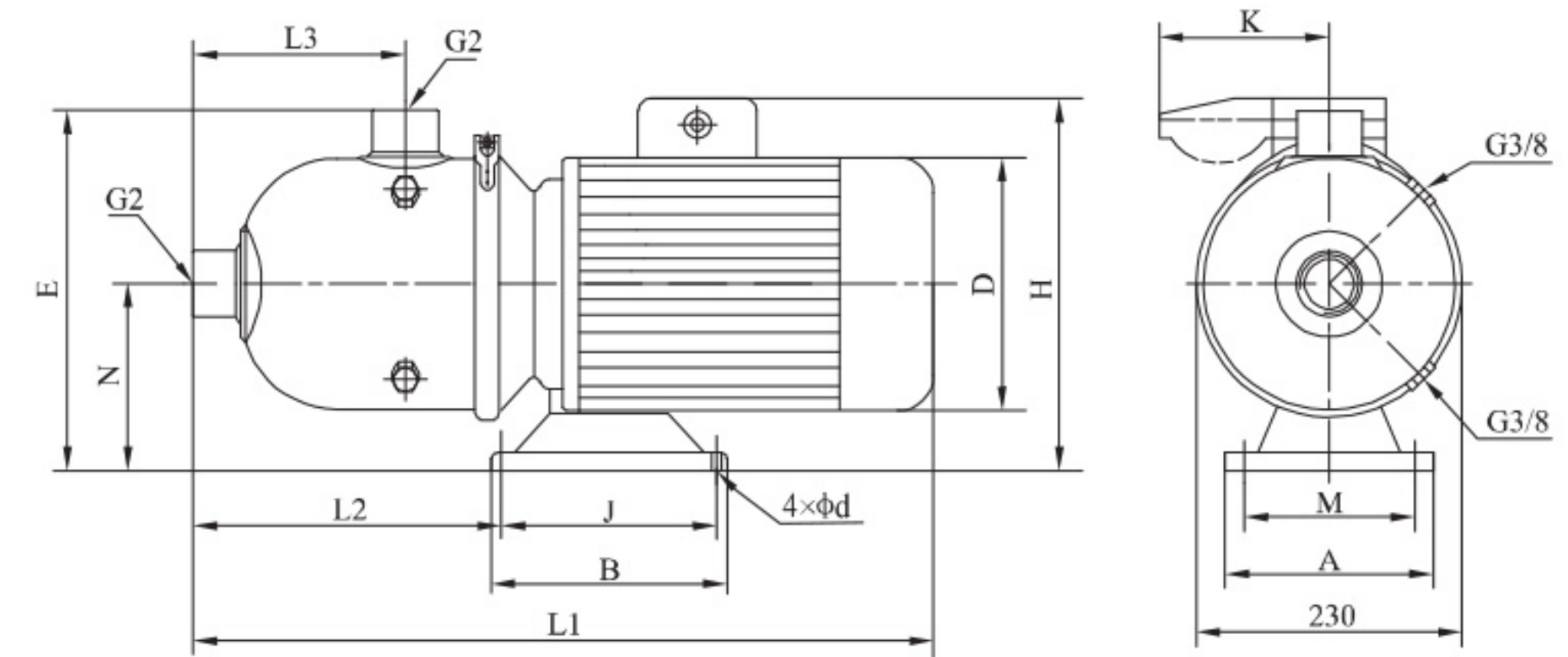

Size and weight

Motor	Model	Size (mm)														Weight (kg)
		L1	L2	L3	N	E	G	A	M	B	J	d	D	H	K	
Three-phase/ single-phase	CHL20-10	563	279	176	118	265	223	130	108	160	138	9	171/176	235/270	/91	26
	CHL20-10G	490	199	95	118	250	193	130	108	160	138	9	171/176	235/270	/91	25.5
	CHL20-20	612	357	176	120	267	223	220	190	170	140	12	213/	270/		43
	CHL20-20G	532	275	95	120	251	193	220	190	170	140	12	213/	270/		42.5
	CHL20-30	661	369	176	132	279	223	248	216	190	140	12	255/	300/		56

Performance curve

ISO9906:2012,3B

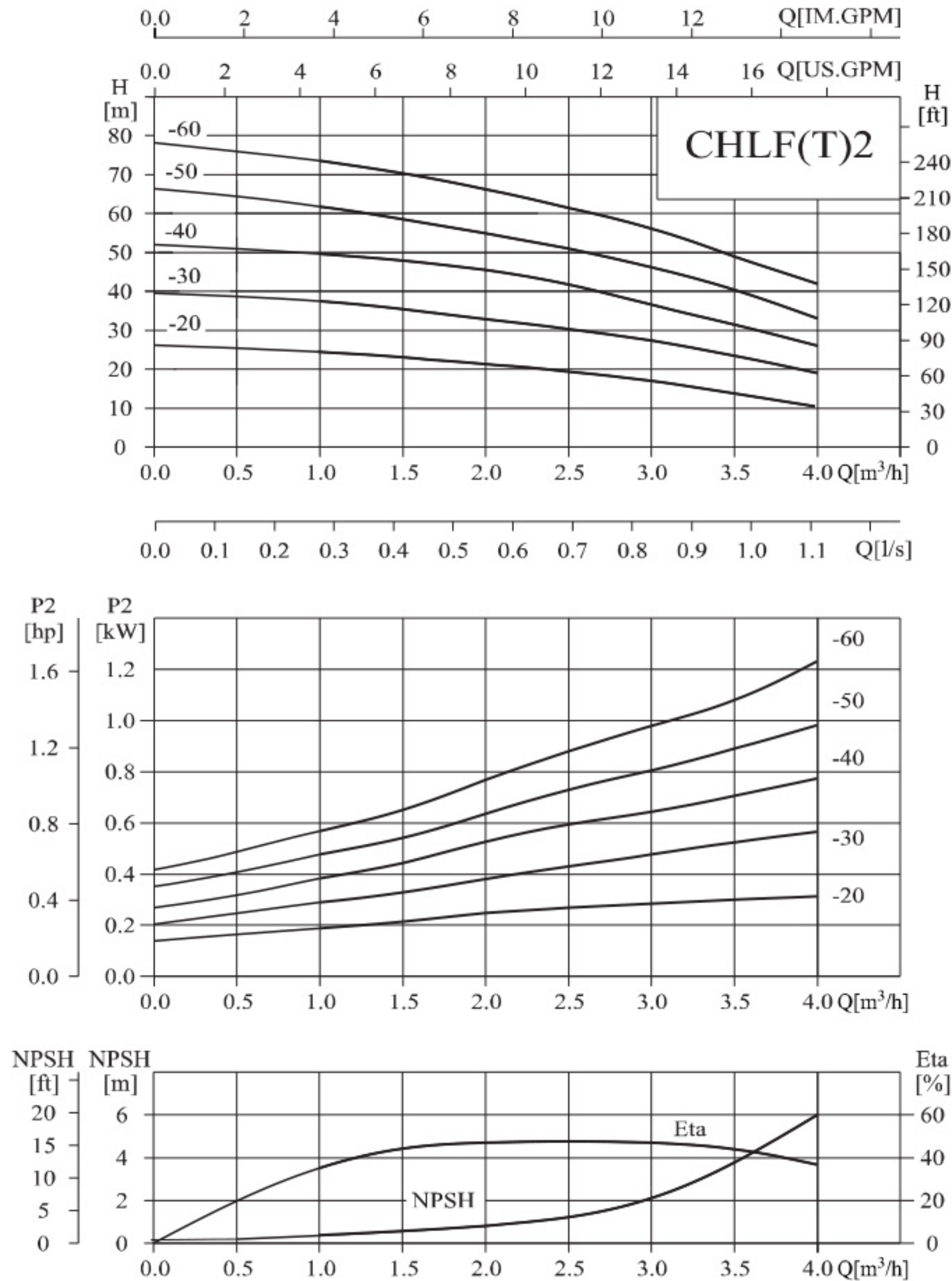

Performance table

Model	Driving motor		Q (m³/h)	1	1.5	2	2.5	3	3.5	4
	(kW)	(hp)								
CHLF(T)2-20	0.55	0.75	H (m)	24.5	23	21.5	19.5	17	14	10.5
CHLF(T)2-30	0.75	1		37.5	35.5	33	30.5	27.5	23.5	19
CHLF(T)2-40	1.1	1.5		49.5	48	45.5	42	36	32	26
CHLF(T)2-50	1.1	1.5		62	58.5	55	51	46	40.5	33
CHLF(T)2-60	1.1	1.5		73.5	70.5	66	61.5	56	49	40

Installation sketch

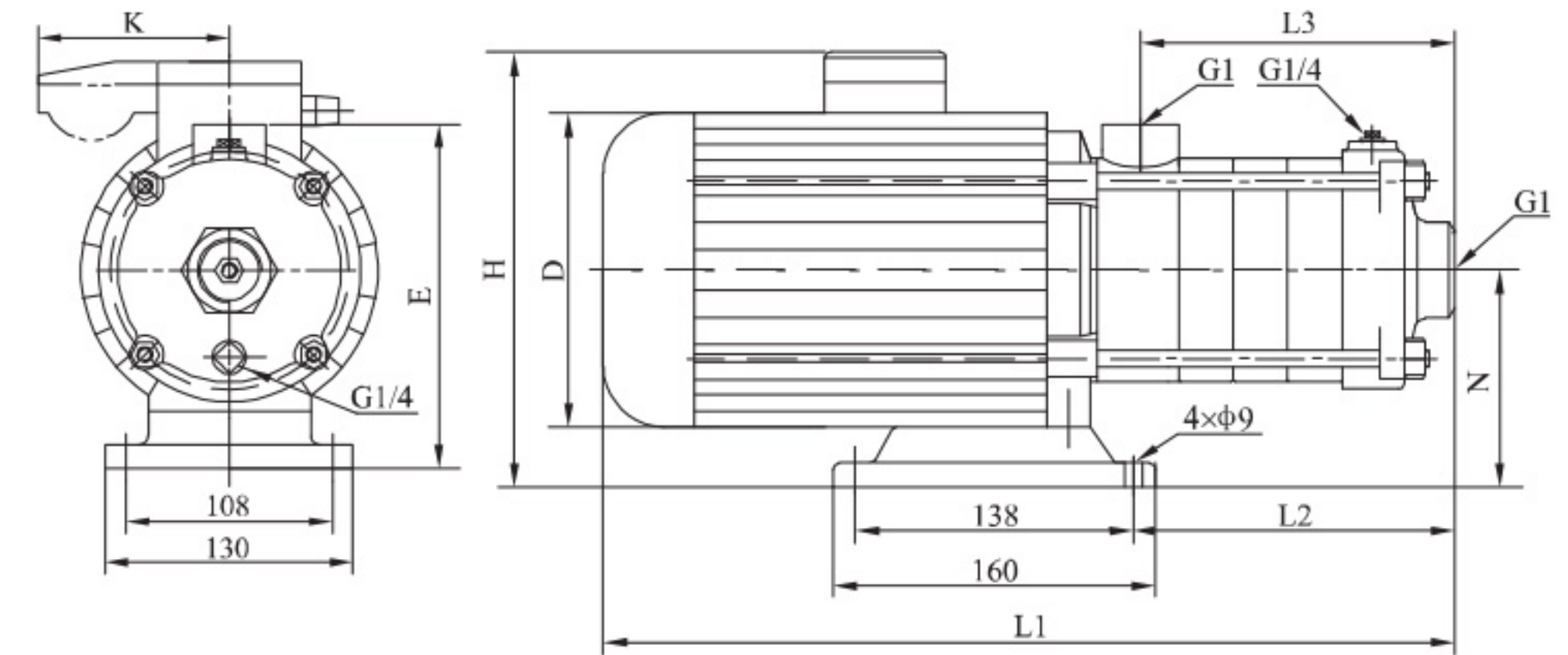

Size and weight

Motor	Model	Size (mm)								Weight (kg)
		L1	L2	L3	E	H	N	D	K	
Three-phase/ single-phase	CHLF(T)2-20	305	87	84	182	230/230	110	141	/62	15
	CHLF(T)2-30	370	105	102	182	230/245	110	151/161	/91	17
	CHLF(T)2-40	388	123	120	182	230/245	110	151/161	/91	17
	CHLF(T)2-50	406	141	138	182	230/245	110	151/161	/91	17
	CHLF(T)2-60	424	159	156	182	230/245	110	151/161	/91	17

Performance curve

ISO9906:2012,3B

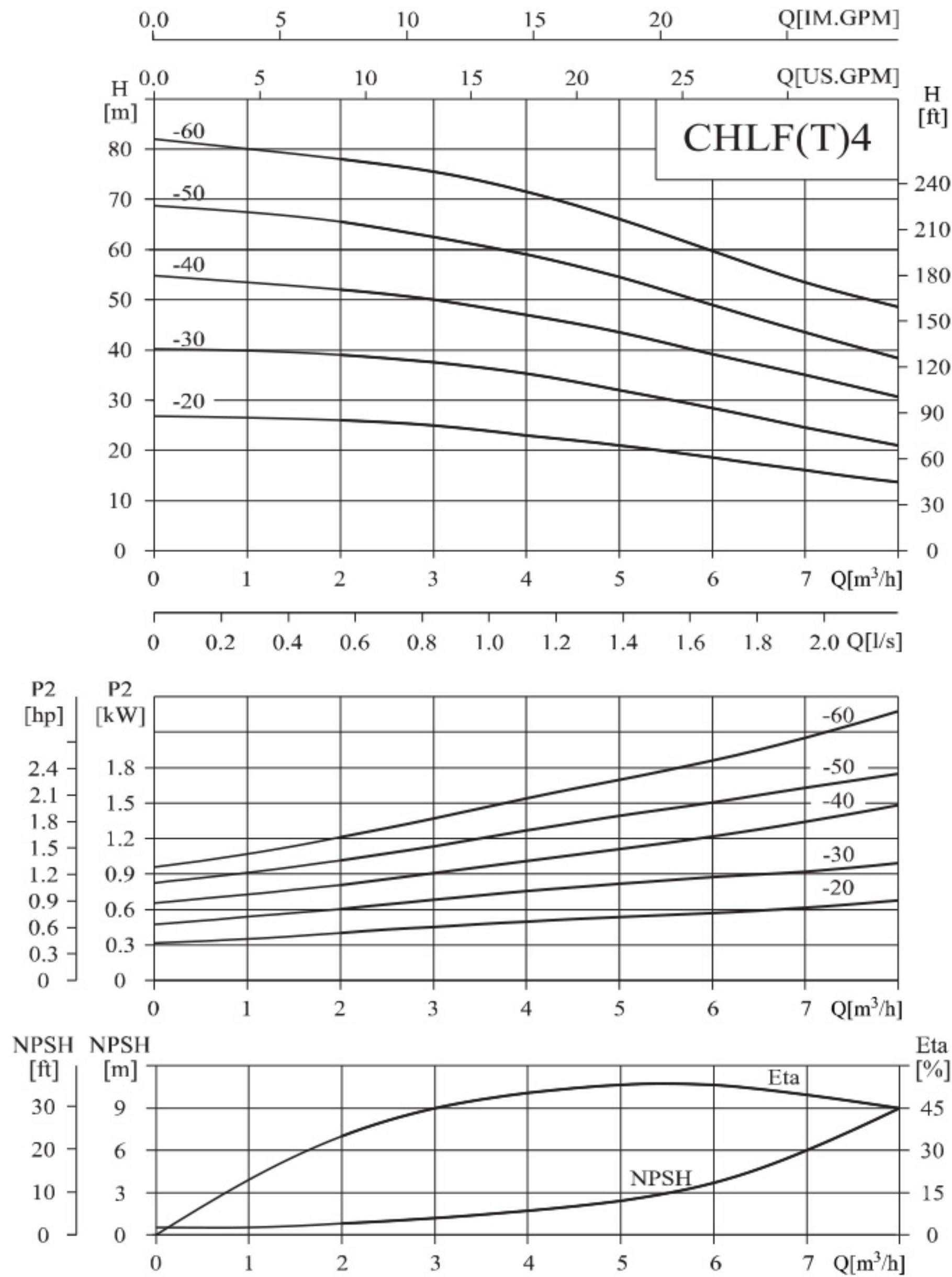

Performance table

Model	Driving motor		Q (m³/h)	2	3	4	5	6	7	8
	(kW)	(hp)								
CHLF(T)4-20	0.75	1	H (m)	26	25	23	21	19	16	14
CHLF(T)4-30	1.1	1.5		39	37.5	36	32	28	24	21
CHLF(T)4-40	1.5	2		52	50	47	43.5	38.5	35	31
CHLF(T)4-50	2.2	3		65.5	62.5	59	54.5	49	43	39
CHLF(T)4-60	2.2	3		78	75.5	71.5	66.5	59	53.5	47

Installation sketch

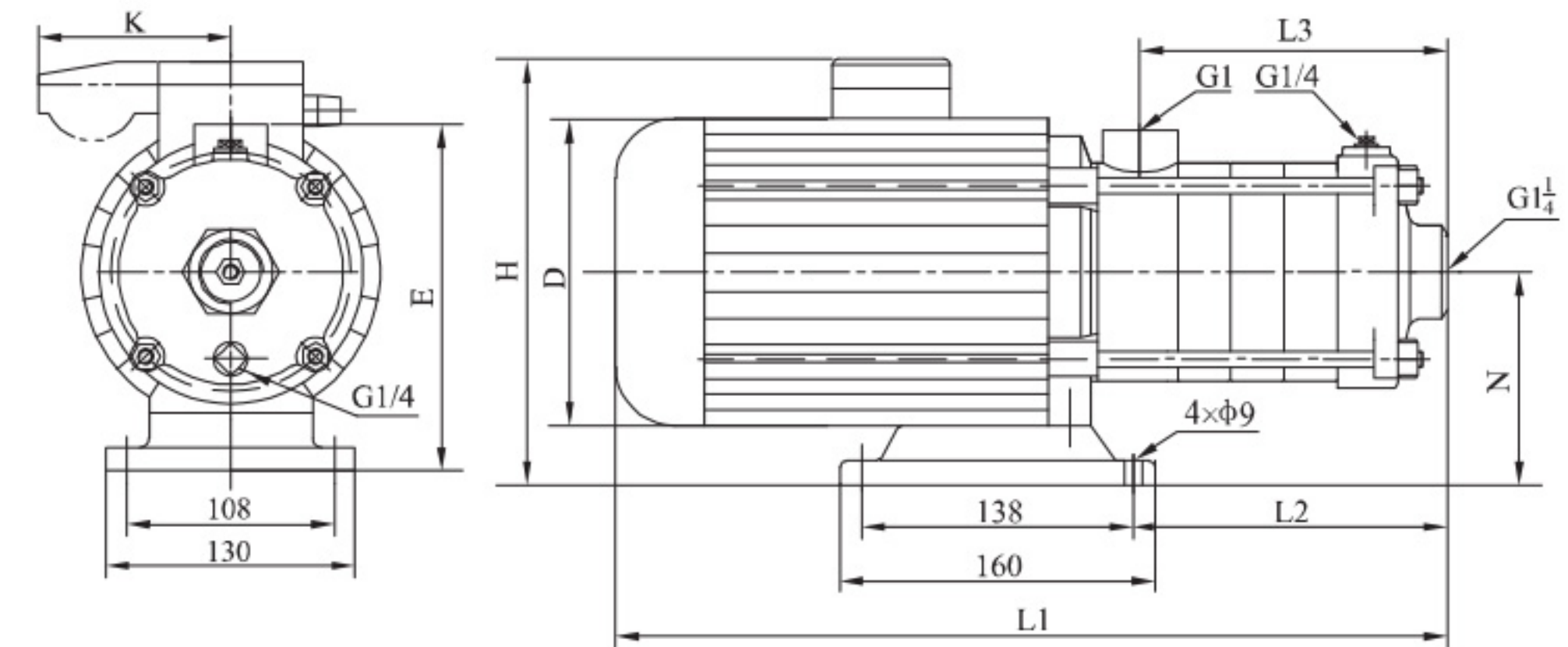

Size and weight

Motor	Model	Size (mm)								Weight (kg)
		L1	L2	L3	E	H	N	D	K	
Three-phase/ single-phase	CHLF(T)4-20	359	105	102	182	230/245	110	151/161	/91	15
	CHLF(T)4-30	395	132	129	182	230/245	110	151/161	/91	17
	CHLF(T)4-40	465	159	156	190	240/260	118	171/176	/91	20
	CHLF(T)4-50	492	186	183	190	240/260	118	171/176	/91	25
	CHLF(T)4-60	519	213	210	190	240/260	118	171/176	/91	25

Performance curve

ISO9906:2012,3B

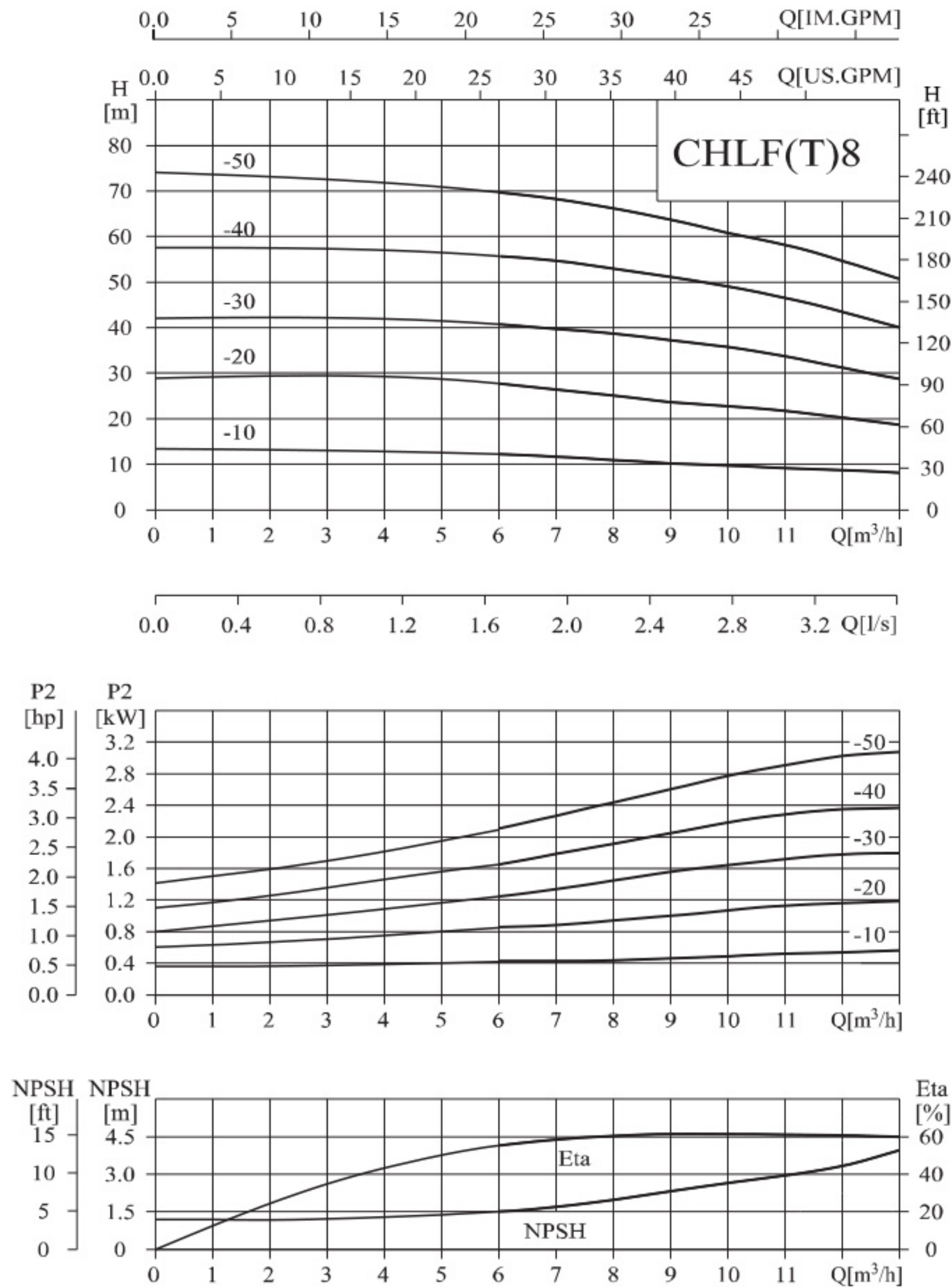

Performance table

Model	Driving motor		Q (m³/h)	6	7	8	9	10	11	12	13
	(kW)	(hp)									
CHLF(T)8-10	0.75	1	H (m)	14.5	13	12	11.5	11	10.5	10	9.5
CHLF(T)8-20	1.5	2		29	27	26	25	24	23	21.5	20
CHLF(T)8-30	2.2	3		42	41	40	39	37	35	33	30
CHLF(T)8-40	3	4		55.5	54.5	53	51	49	46.5	43.5	40
CHLF(T)8-50	3	4		71	69.5	67.5	65	63	59	56	52

Installation sketch

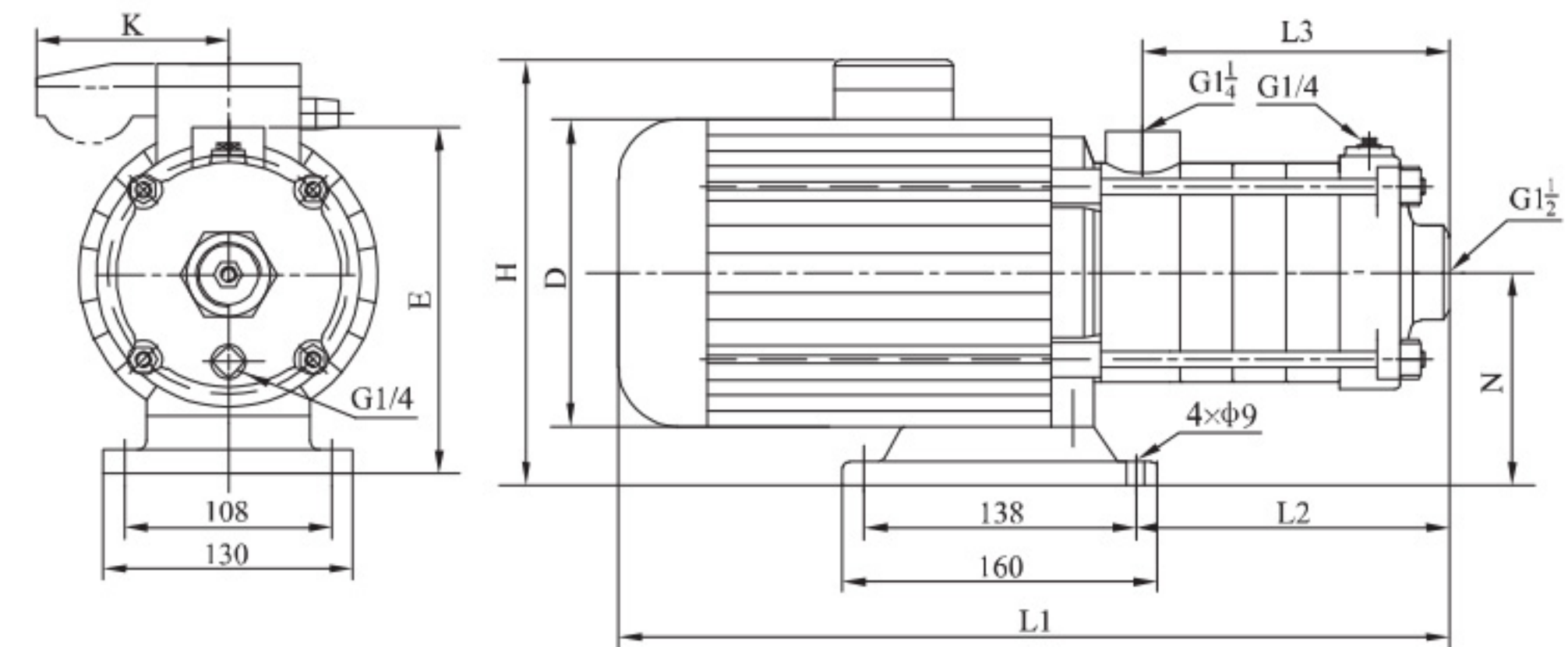

Size and weight

Motor	Model	Size (mm)								Weight (kg)
		L1	L2	L3	E	H	N	D	K	
Three-phase/ single-phase	CHLF(T)8-10	395	128	108	227	230/265	117	151/156	/91	22
	CHLF(T)8-20	430	128	108	228	240/270	118	171/176	/91	25
	CHLF(T)8-30	460	158	138	228	240/270	118	171/176	/91	27
	CHLF(T)8-40	550	188	168	238	259/	128	197/		32
	CHLF(T)8-50	580	218	198	238	259/	128	197/		32

Performance curve

ISO9906:2012,3B

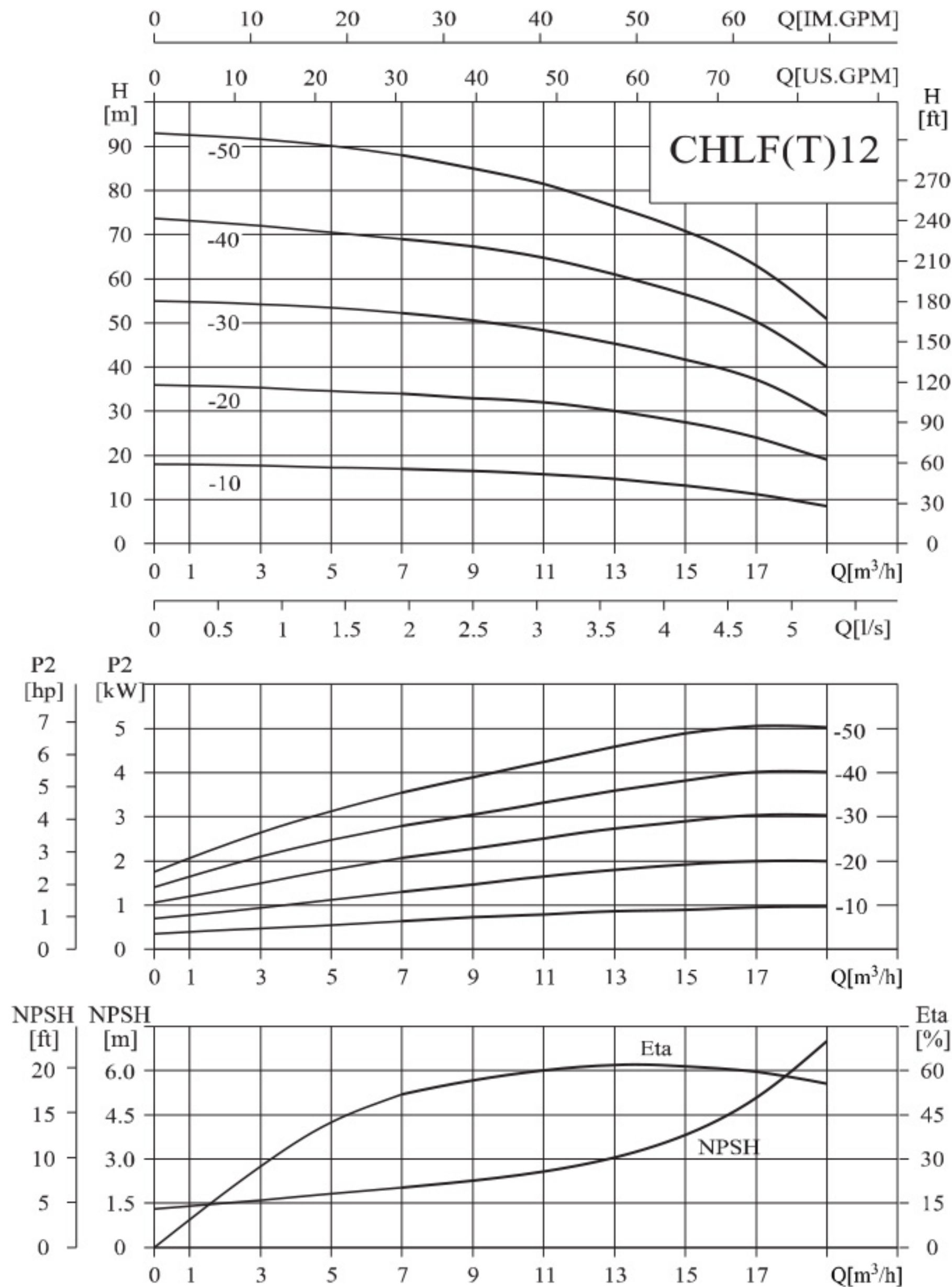

Performance table

Model	Driving motor		Q (m³/h)	7	9	11	12	13	15	17	19
	(kW)	(hp)									
CHLF(T)12-10	1.1	1.5	H (m)	17	16	15	14.5	14	12.5	11	8.5
CHLF(T)12-20	2.2	3		34	33	32	31	30	27	24.5	19
CHLF(T)12-30	3	4		52.5	50	48.5	47	45	41.5	37.5	29
CHLF(T)12-40	4	5.5		69	67.5	65	63	60.5	55	49.5	40
CHLF(T)12-50	5.5	7.5		88	85	82	80	76	70	62	50.5

Installation sketch

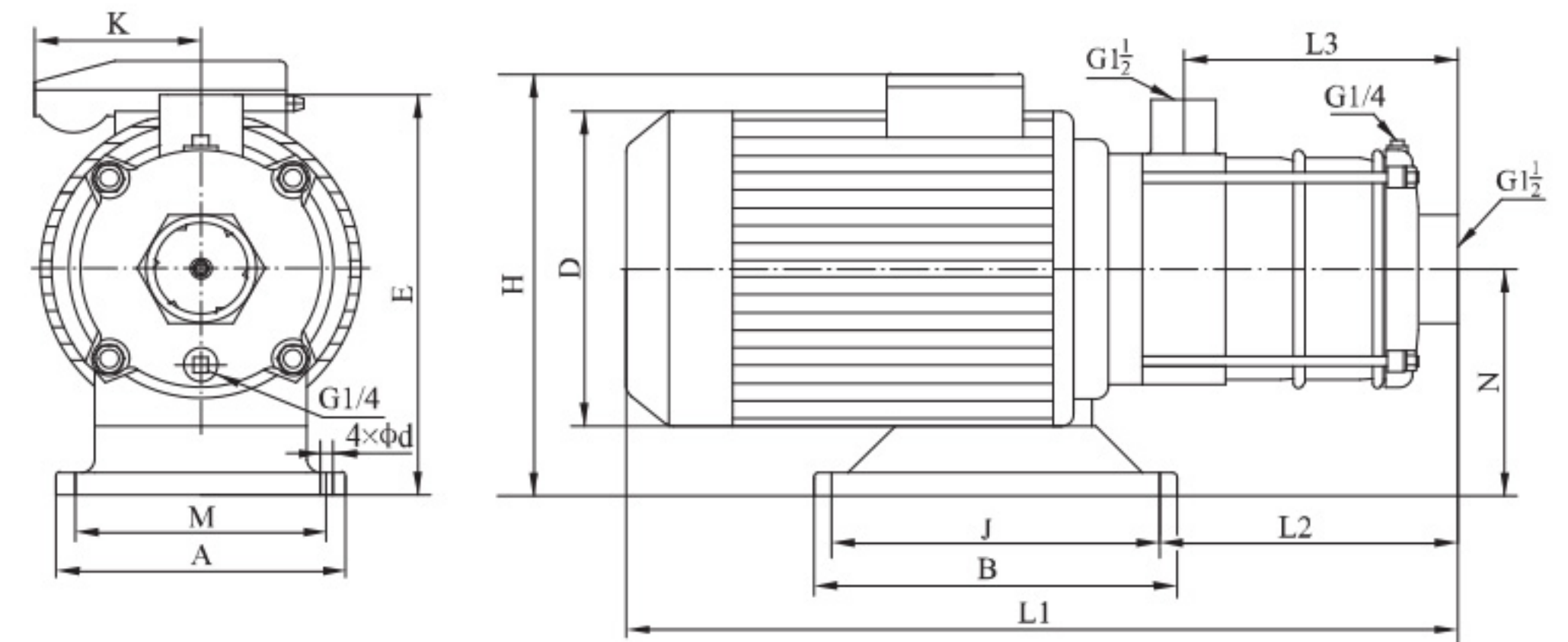

Size and weight

Motor	Model	Size (mm)													Weight (kg)
		L1	L2	L3	H	D	E	N	A	M	B	J	d	K	
Three-phase/ single-phase	CHLF(T)12-10	375/395	125	108	230/265	151/156	227	117	130	108	160	138	9	/91	22
	CHLF(T)12-20	415/426	125	108	240/270	171/176	228	118	130	108	160	138	9	/91	25
	CHLF(T)12-30	501/	155	138	259/	197/	238	128	130	108	160	138	9		32
	CHLF(T)12-40	537/	281	168	270/	213/	230	120	220	190	170	140	12		44
	CHLF(T)12-50	618/	324	198	300/	255/	242	132	248	216	184	140	12		58

Performance curve

ISO9906:2012,3B

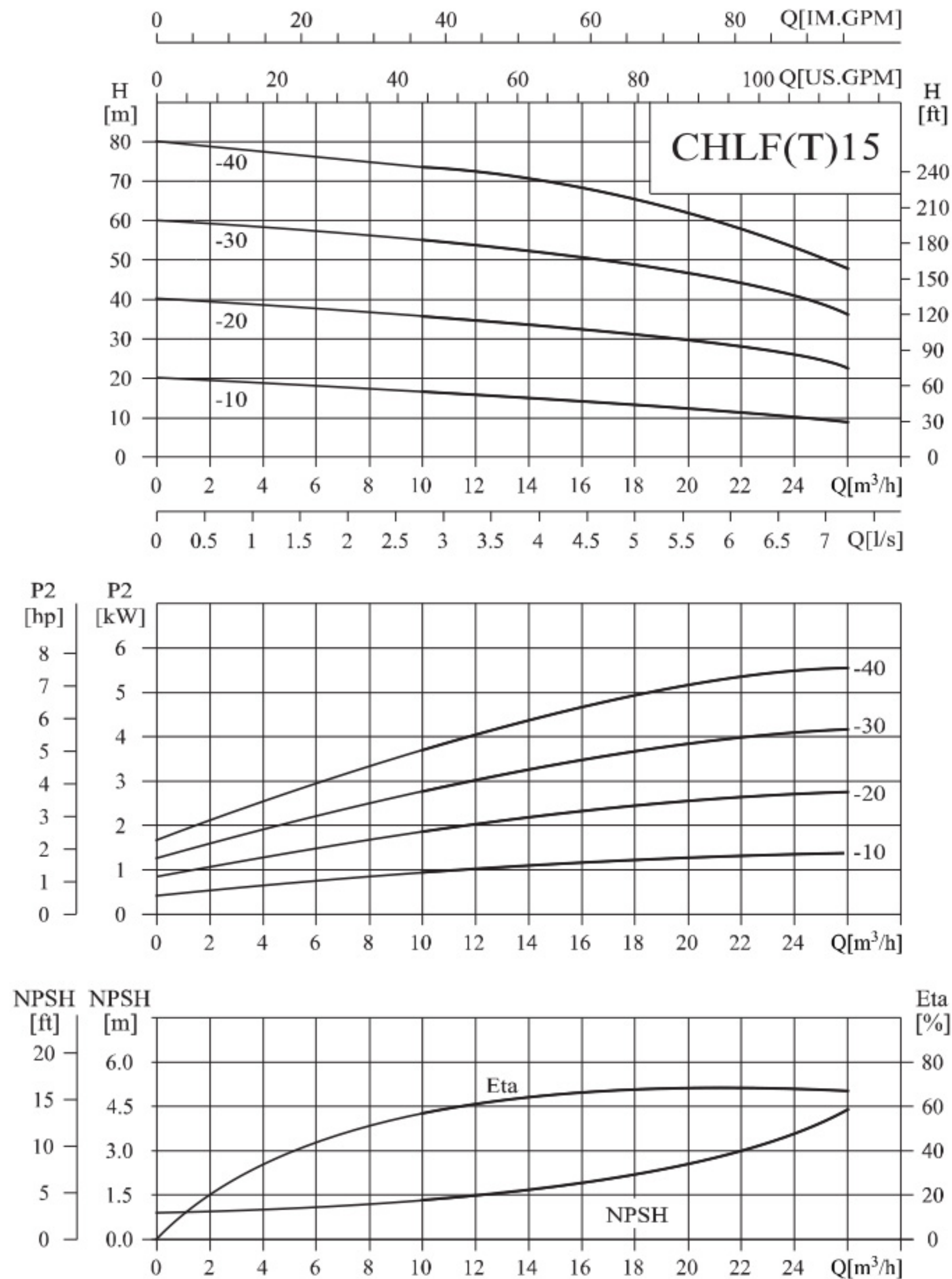

Performance table

Model	Driving motor		Q (m³/h)	10	12	14	15	16	18	20	22	24	26
	(kW)	(hp)		H (m)									
CHLF(T)15-10	1.5	2		17	15.5	14.5	14	13.5	13	12	11	10	9
CHLF(T)15-20	3	4		35.5	34.5	33.5	33	32.5	31	30	28	26	23
CHLF(T)15-30	4	5.5		55	53.5	52.5	51.5	51	49	47	44	41	36.5
CHLF(T)15-40	5.5	7.5		73.5	72.5	70.5	69.5	68.5	65.5	62	58	54	48

Installation sketch

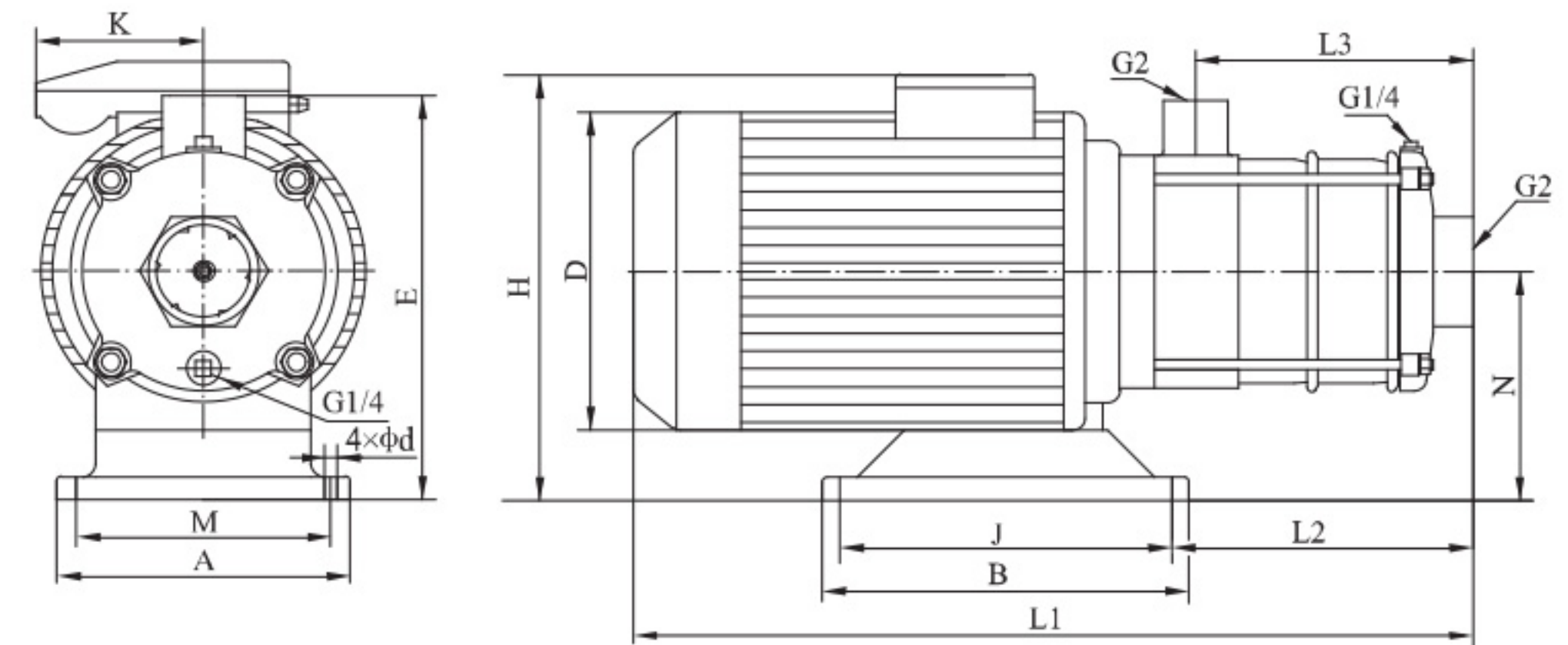

Size and weight

Motor	Model	Size (mm)											Weight (kg)		
		L1	L2	L3	H	D	E	N	A	M	B	J		d	K
Three-phase/ single-phase	CHLF(T)15-10	440/451	150	126	240/270	171/176	228	118	130	108	160	138	9	/91	24
	CHLF(T)15-20	499/	150	126	259/	197/	238	128	130	108	160	138	9		36
	CHLF(T)15-30	550/	291	171	270/	213/	230	120	220	190	170	140	12		45
	CHLF(T)15-40	646/	349	216	300/	255/	242	132	248	216	184	140	12		54

Performance curve

ISO9906:2012,3B

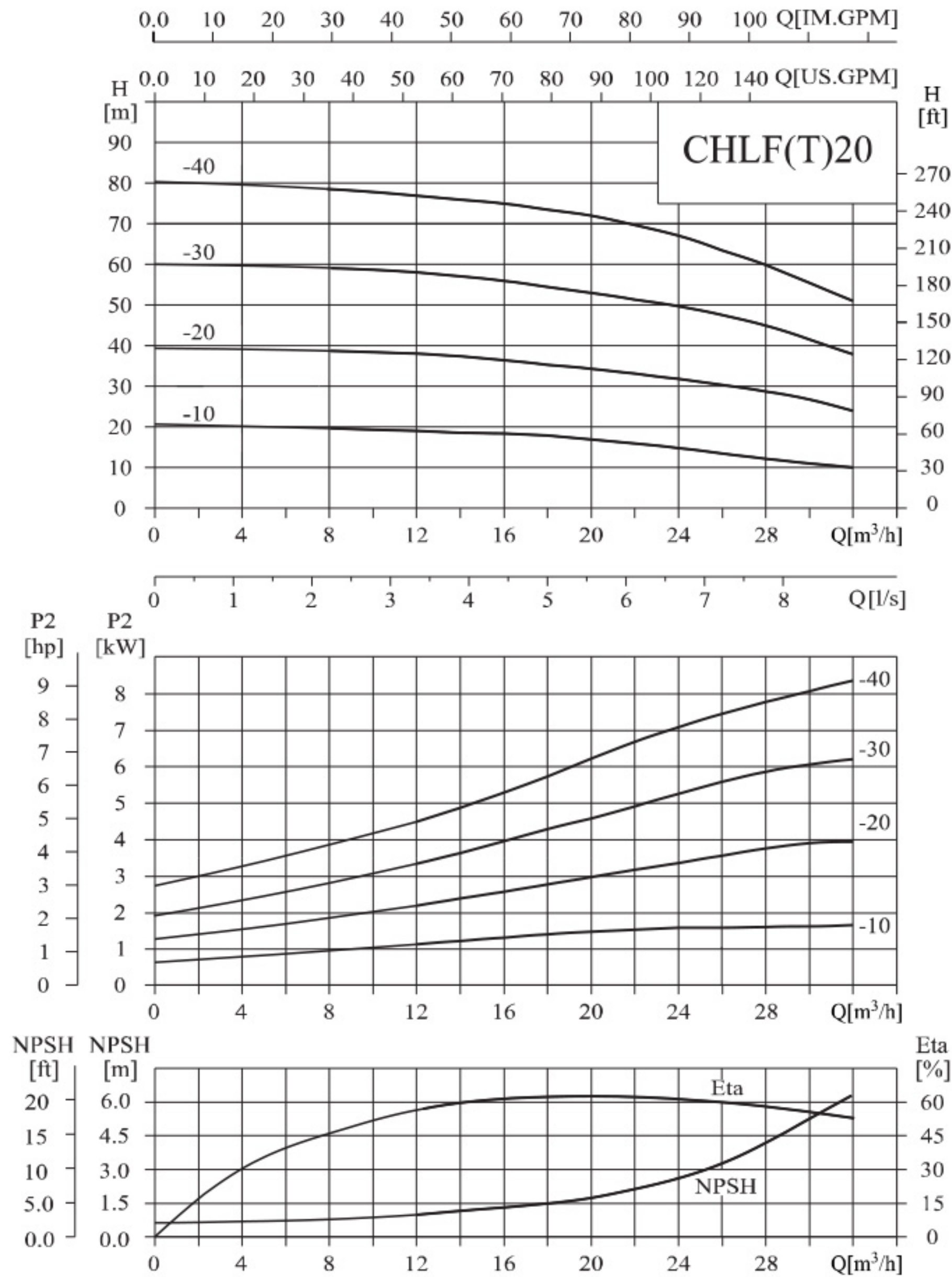

Performance table

Model	Driving motor		Q (m³/h)	12	14	16	18	20	22	24	26	28	30	32
	(kW)	(hp)		H (m)										
CHLF(T)20-10	2.2	3		19	18.5	18	17.5	17	16	15	13.5	12	11	10
CHLF(T)20-20	4	5.5		38	37	36	35	34	33	32	30.5	29	26.5	24
CHLF(T)20-30	5.5	7.5		58	57	56	55	53	51.4	50	47.5	45	41.6	38
CHLF(T)20-40	7.5	10		77	76	75	73.5	72	70	67	65	60.5	56	51

Installation sketch

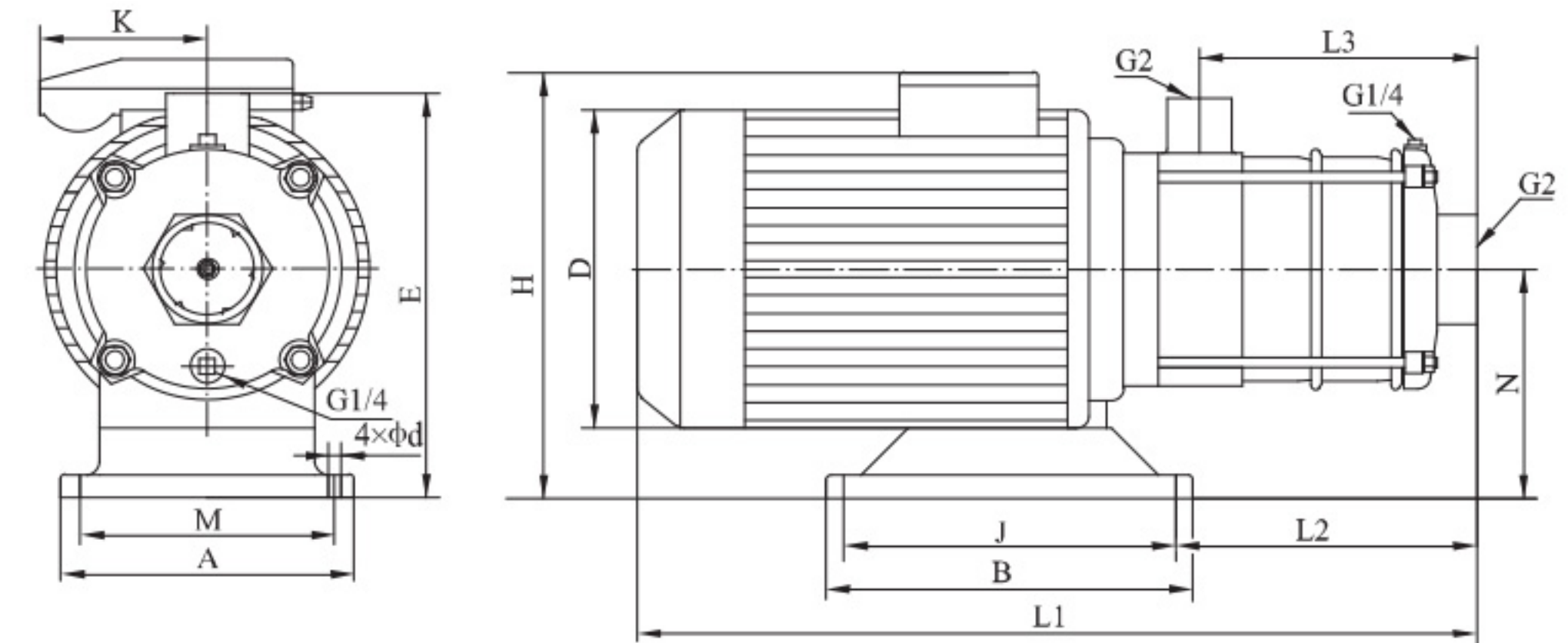

Size and weight

Motor	Model	Size (mm)												Weight (kg)	
		L1	L2	L3	H	D	E	N	A	M	B	J	d		K
Three-phase/ single-phase	CHLF(T)20-10	440/451	150	126	240/270	171/176	228	118	130	108	160	138	9	/91	26
	CHLF(T)20-20	502	246	126	270/	213/	230	120	220	190	170	140	12		43
	CHLF(T)20-30	598/	304	171	300/	255/	242	132	248	216	184	140	12		56
	CHLF(T)20-40	643/	349	216	300/	255/	242	132	248	216	184	140	12		63